

NOTE: All Assembly Order Numbers are for bead plate parts unless noted otherwise.

	Description	Assembly Order No.
Style	Blind nuts, 1/4 BSP	W01-M58-6155
131	Socket head aluminum bead rings (bolts, nuts, washers not included-use M6 cap screws)	W01-358-0127
Two Ply Bellows	Rubber bellows only	W01-358-0131
Assembly weight.....		1.2 kg.
Force to collapse to minimum height (@ 0 BAR)		142 N.

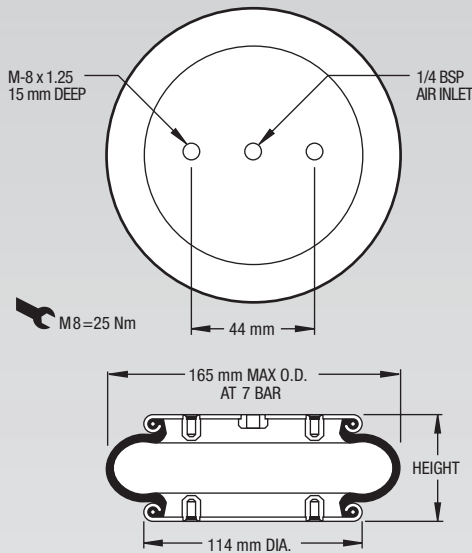

NOTE: A bead plate part is shown. This part is also available with bead rings. Bolts are not included. See pages 8-10 for explanation.

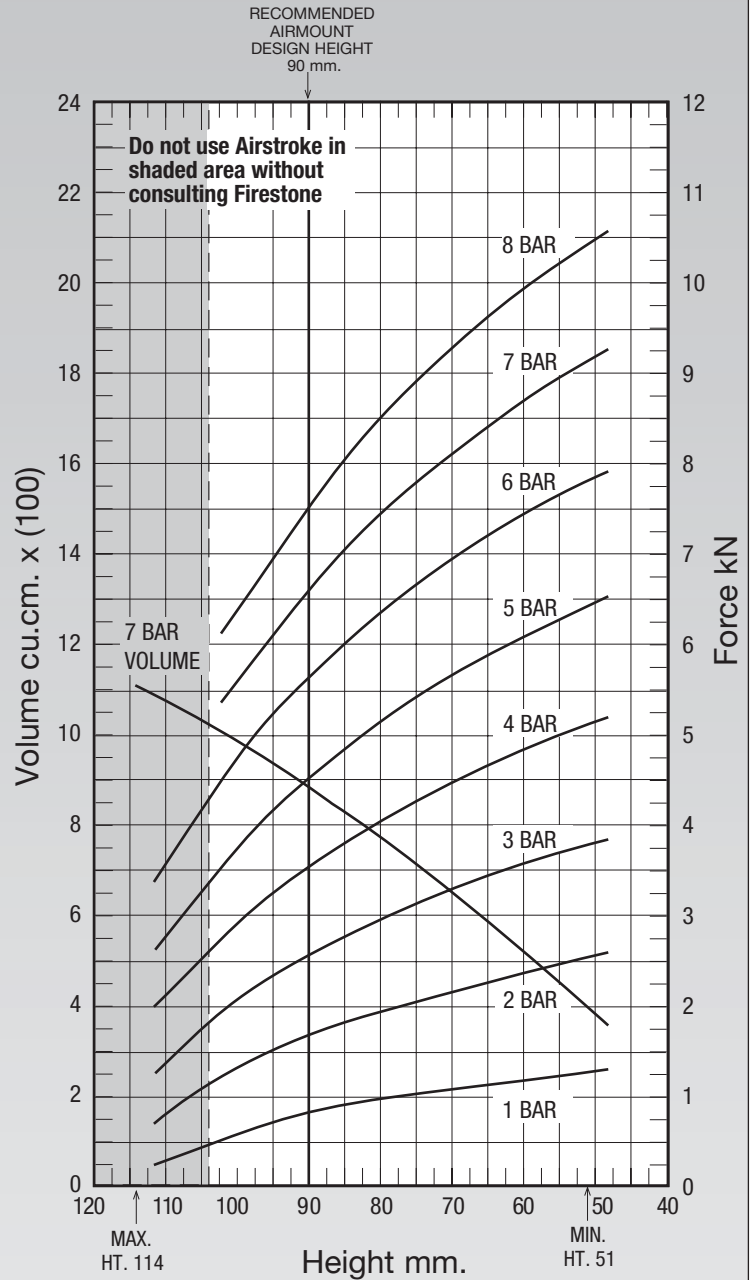

See page 12 for instructions on how to use chart.

Dynamic Characteristics at 90 mm Design Height (Required for Airmount isolator design only)			
Gauge Pressure (BAR)	Load (kN)	Spring Rate (kN/m)	Natural Frequency Hz
3	2.50	103	3.20
4	3.51	133	3.07
5	4.48	162	3.00
6	5.57	193	2.93
7	6.54	221	2.90

Force Table (Use for Airstroke™ actuator design)							
Assembly Height (mm)	Volume @ 7 BAR (cu cm)	EFF Area @ 7 BAR (cm ²)	kN Force				
			@ 3 BAR	@ 4 BAR	@ 5 BAR	@ 6 BAR	@ 7 BAR
100	982	78	1.96	2.83	3.65	4.63	5.48
90	880	93	2.50	3.51	4.48	5.57	6.54
80	774	105	2.90	4.01	5.10	6.30	7.38
70	652	115	3.23	4.44	5.61	6.91	8.08
60	529	124	3.51	4.79	6.05	7.41	8.65