

	Description	Assembly Order No.
Style 126	Ribbed neck aluminum bead rings (equal spacing), 1 7/8 bolts, nuts, washers	W01-358-7727
Two Ply Bellows	Rolled Plate Assembly*, 1/2 blind nuts, 3/4 NPT	W01-358-7726
	Rubber bellows only	W01-358-1026
Assembly weight.....		16.6 lbs.
Force to collapse to minimum height (@ 0 PSIG)		25 lbs.

Recommended Design Position Static Pressure 0-100 psi

RECOMMENDED AIRMOUNT DESIGN HEIGHT 5.0 INCHES

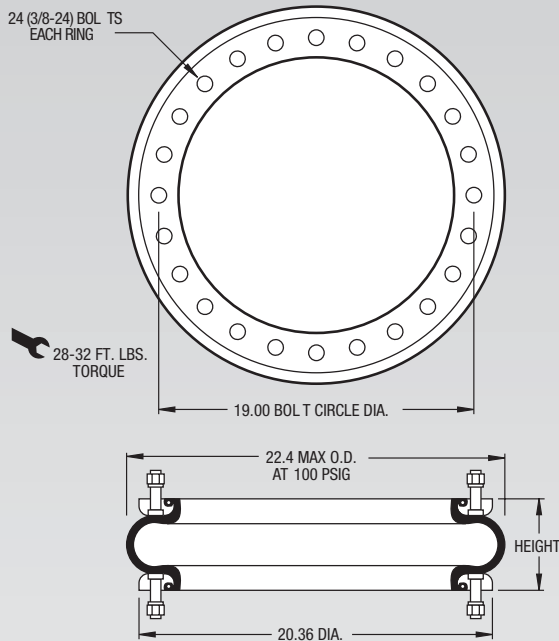

NOTE: A bead ring part is shown. This part is also available with rolled plates. See page 11 for explanation.

*Increase the minimum height by .70 inch. Add .70 inch to the height (bottom axis) before reading loads.

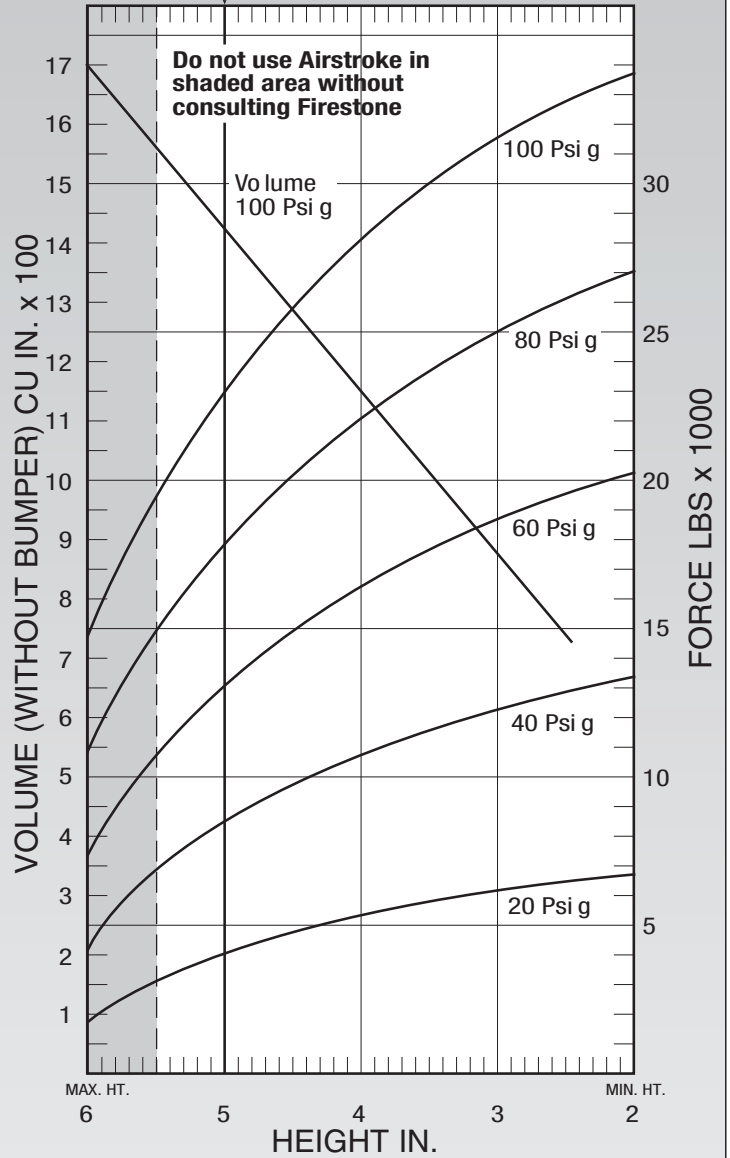

See page 12 for instructions on how to use chart.

Dynamic Characteristics at 5.0 in. Design Height (Required for Airmount isolator design only)				
Volume @ 100 PSIG = 1,315 in ³			Natural Frequency	
Gage Pressure (PSIG)	Load (lbs.)	Spring Rate (lbs./in.)	Natural Frequency	
			CPM	HZ
40	8,630	5,869	155	2.59
60	13,870	5,244	144	2.42
80	18,450	10,107	139	2.32
100	23,200	12,403	137	2.29

Force Table (Use for Airstroke™ actuator design)						
Assembly Height (in.)	Volume @ 100 PSIG (in ³)	Pounds Force				
		@20 PSIG	@40 PSIG	@60 PSIG	@80 PSIG	@100 PSIG
6.0	1,694	1,800	4,000	7,100	10,900	15,000
5.0	1,473	4,220	8,630	13,870	18,450	23,200
4.0	1,196	5,200	10,840	16,630	22,460	28,070
3.0	875	6,010	12,040	19,020	25,960	32,000