

Description		Assembly Order No.
Style 2M2A	Blind nut, 1/8 NPT, plastic studs	WO2-358-3008
Two Ply Bellows		
Assembly weight . . . . .		0.15 lbs.
Force to collapse to minimum height (@ 0 PSIG) . . .		5 lbs.

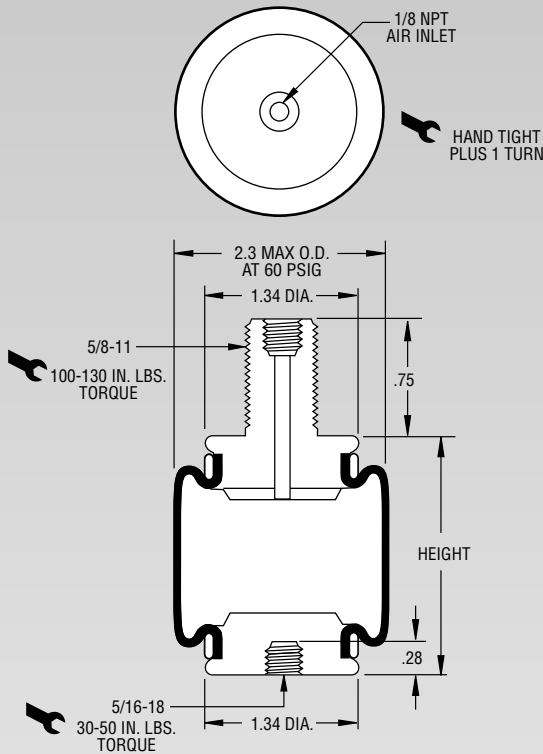

**NOTE:** This Airstroke actuator must be guided throughout the stroke.

**NOTE:** The 2M2A is laterally unstable when used unsupported as an isolator. Contact Firestone for use in isolation applications.

Dynamic Characteristics at 1.8 in. Design Height (Required for Airmount isolator design only)				
Volume @ 100 PSIG = 4.52 in <sup>3</sup>			Natural Frequency	
Gage Pressure (PSIG)	Load (lbs.)	Spring Rate (lbs./in.)	CPM	HZ
40	84	110	215	3.59
60	120	156	214	3.57
80	158	201	212	3.53
100	198	247	210	3.50

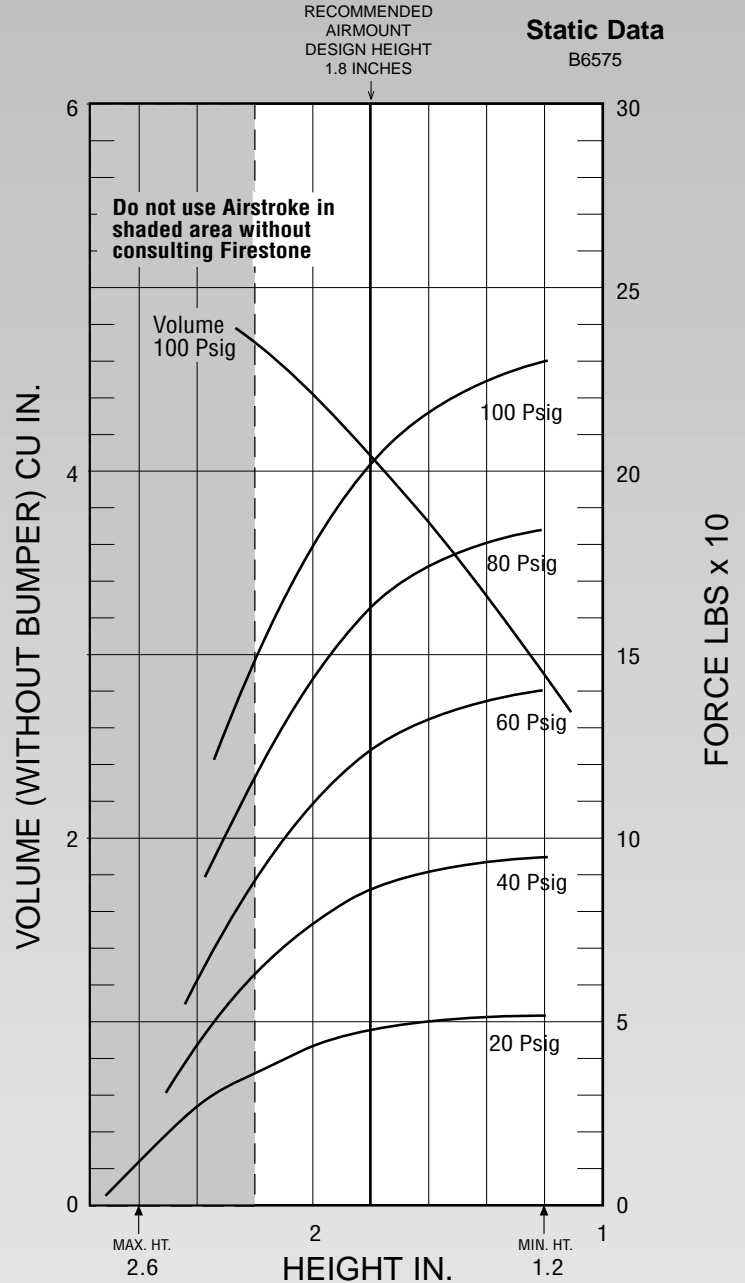

See page 12 for instructions on how to use chart.

Force Table (Use for Airstroke® actuator design)						
Assembly Height (in.)	Volume @ 60 PSIG (in <sup>3</sup> )	Pounds Force				
		@20 PSIG	@40 PSIG	@60 PSIG	@80 PSIG	@100 PSIG
1.2	2.92	52	94	138	184	229
1.4	3.36	50	92	135	180	224
1.6	3.78	48	89	130	172	214
1.8	4.17	46	84	120	158	198
2	4.52	41	73	105	137	172
2.2	4.79	34	58	84	108	138