

Description		Assembly Order No.
Style 21-2	Blind nuts, 1/4 NPT	WO1-358-6800
Two Ply Bellows	Blind nuts, 1/4 NPT, rubber bumper	WO1-358-6801
	Blind nuts, 3/4 NPT	WO1-358-9529
Assembly weight		18.2 lbs
Force to collapse to minimum height (@ 0 PSIG).....		35 lbs.

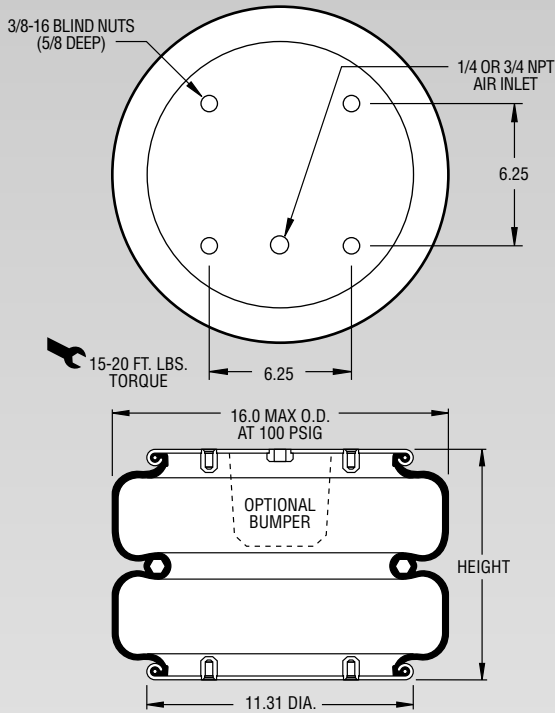

NOTE: The bellows extends beyond the bead plates at minimum height.

NOTE: A bead plate part is shown. This part is also available with bead rings. See pages 8-10 for explanation.

Dynamic Characteristics at 10.5 in. Design Height (Required for Airmount isolator design only)				
Volume @ 100 PSIG = 1,462 in ³			Natural Frequency	
Gage Pressure (PSIG)	Load (lbs.)	Spring Rate (lbs./in.)	CPM	HZ
40	3,460	989	100	1.67
60	5,350	1,437	97	1.62
80	7,280	1,850	95	1.58
100	9,210	2,247	93	1.55

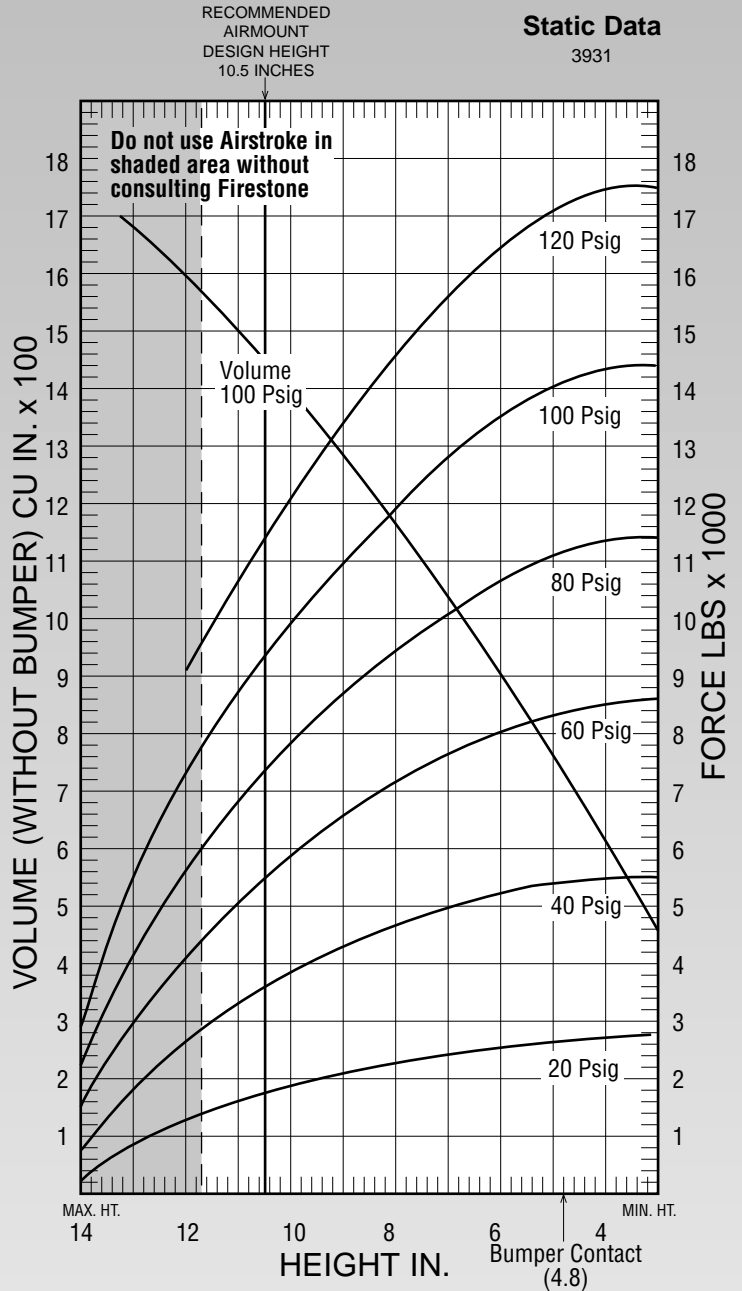

See page 12 for instructions on how to use chart.

Force Table (Use for Airstroke [®] actuator design)						
Assembly Height (in.)	Volume @ 100 PSIG (in ³)	Pounds Force				
		@20 PSIG	@40 PSIG	@60 PSIG	@80 PSIG	@100 PSIG
11.0	1,510	1,540	3,180	4,930	6,730	8,550
10.0	1,410	1,810	3,710	5,730	7,760	9,790
9.0	1,298	2,040	4,150	6,430	8,570	10,780
8.0	1,177	2,240	4,530	7,050	9,290	11,690
7.0	1,048	2,400	4,850	7,570	10,030	12,620
6.0	910	2,530	5,140	8,000	10,670	13,440
5.0	764	2,620	5,370	8,310	11,100	13,990
4.0	615	2,690	5,490	8,490	11,330	14,280