

Description		Assembly Order No.
Style 200	Ribbed neck aluminum bead rings (equal spacing), 1 7/8 bolts, nuts, washers	WO1-358-7772
Two Ply Bellows	Ribbed neck aluminum bead rings (equal spacing) 1 1/4 b,n,w Rubber bellows only	WO1-358-7775 WO1-358-5126
Assembly weight		34.9 lbs
Force to collapse to minimum height (@ 0 PSIG)....		100 lbs.

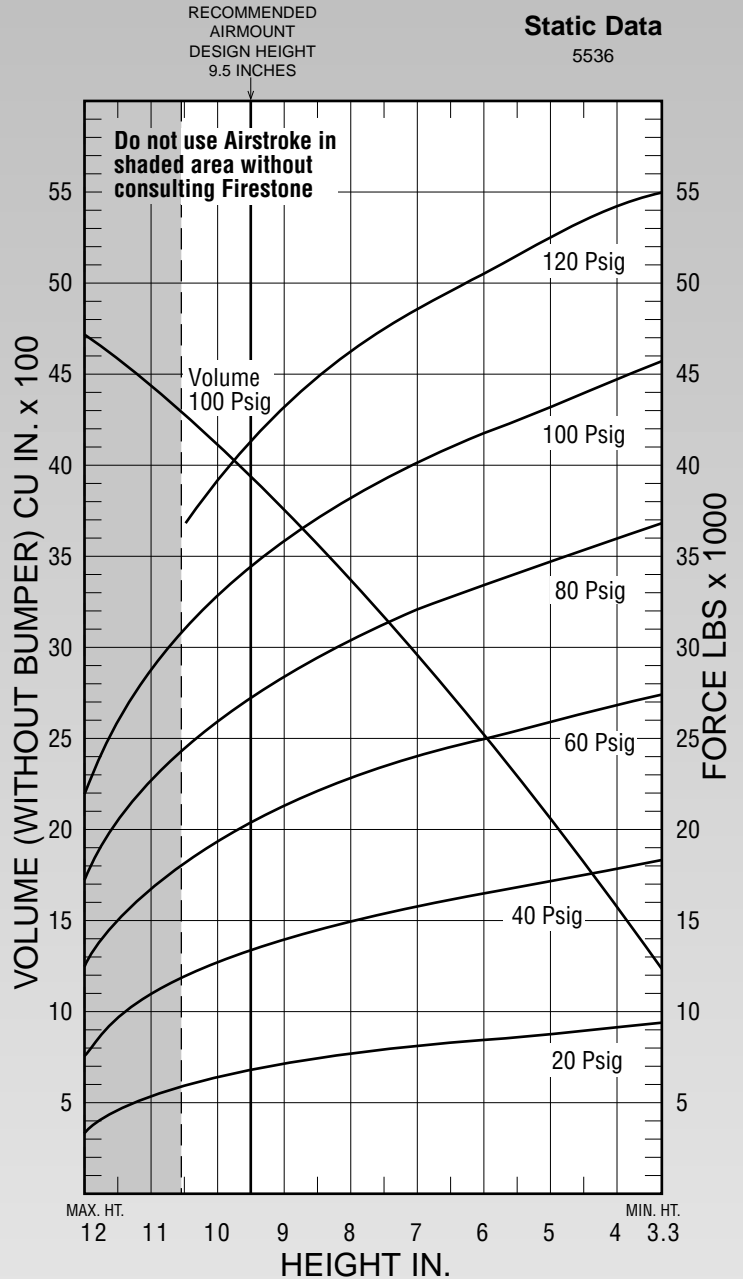
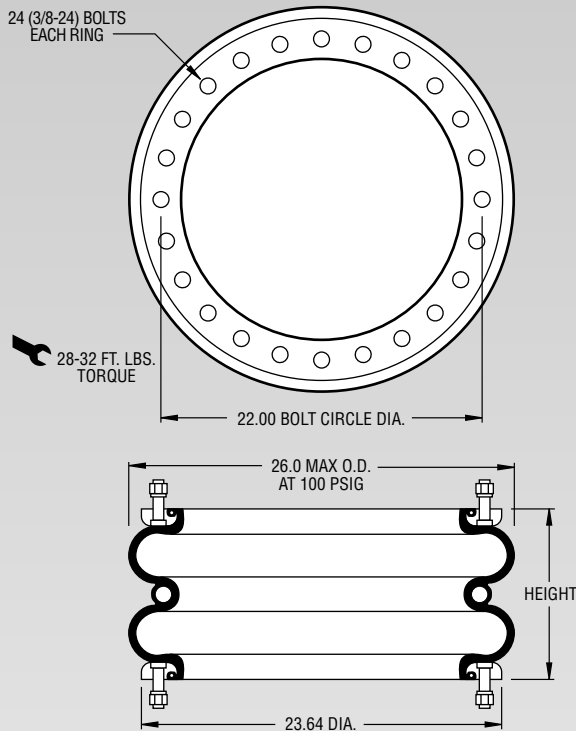

See page 12 for instructions on how to use chart.

Dynamic Characteristics at 9.5 in. Design Height (Required for Airmount isolator design only)				
Volume @ 100 PSIG = 3,921 in ³			Natural Frequency	
Gage Pressure (PSIG)	Load (lbs.)	Spring Rate (lbs./in.)	CPM	HZ
40	13,290	3,784	100	1.67
60	20,390	5,336	96	1.60
80	27,330	6,763	93	1.56
100	34,620	8,105	91	1.51

Force Table (Use for Airstroke® actuator design)						
Assembly Height (in.)	Volume @ 100 PSIG (in ³)	Pounds Force				
		@20 PSIG	@40 PSIG	@60 PSIG	@80 PSIG	@100 PSIG
10.0	4,099	6,270	12,530	19,300	25,970	33,040
9.0	3,734	7,070	13,960	21,360	28,550	36,020
8.0	3,343	7,710	15,070	22,960	30,580	38,450
7.0	2,928	8,180	15,920	24,160	32,200	40,400
6.0	2,495	8,540	16,610	25,110	33,550	41,960
5.0	2,055	8,880	17,280	26,010	34,790	43,400
4.0	1,589	9,260	18,000	26,960	36,020	44,850