

Description		Assembly Order No.
Style 20	Blind nuts, 1/4 NPT	WO1-358-6910
	Blind nuts, 1/4 NPT, bumper	WO1-358-6911
Two Ply Bellows	Blind nuts, 3/4 NPT	WO1-358-6900
	Blind nuts, 3/4 NPT, bumper	WO1-358-6901
	Countersunk steel bead rings, 1 3/4 bolts, nuts, washers	WO1-358-6923
	Rubber bellows only	WO1-358-7901
Assembly weight .....		7.5 lbs.
Force to collapse to minimum height (@ 0 PSIG).....		14 lbs.
Style 202	Blind nuts, 1/4 NPT	WO1-358-7080
	Blind nuts, 3/4 NPT	WO1-358-7119
High Strength Bellows		

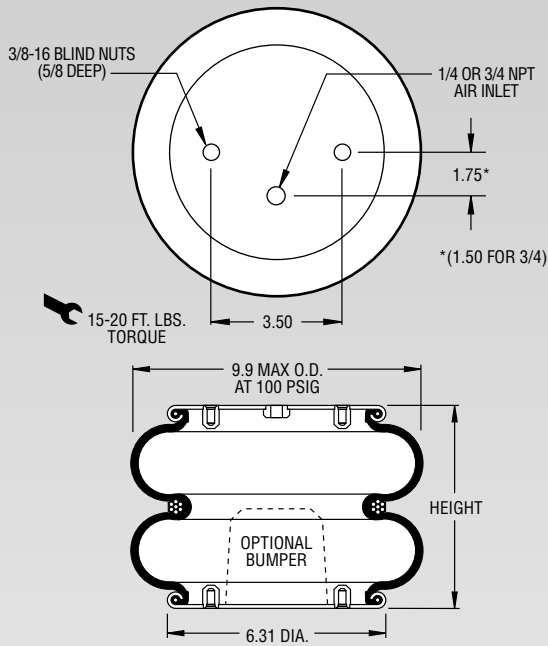

**NOTE: A bead plate part is shown. This part is also available with bead rings. See pages 8-10 for explanation.**

Dynamic Characteristics at 8.5 in. Design Height (Required for Airmount isolator design only)				
Volume @ 100 PSIG = 376 in <sup>3</sup>			Natural Frequency	
Gage Pressure (PSIG)	Load (lbs.)	Spring Rate (lbs./in.)	CPM	HZ
40	990	414	121	2.02
60	1,540	615	119	1.98
80	2,130	820	116	1.94
100	2,720	996	114	1.89

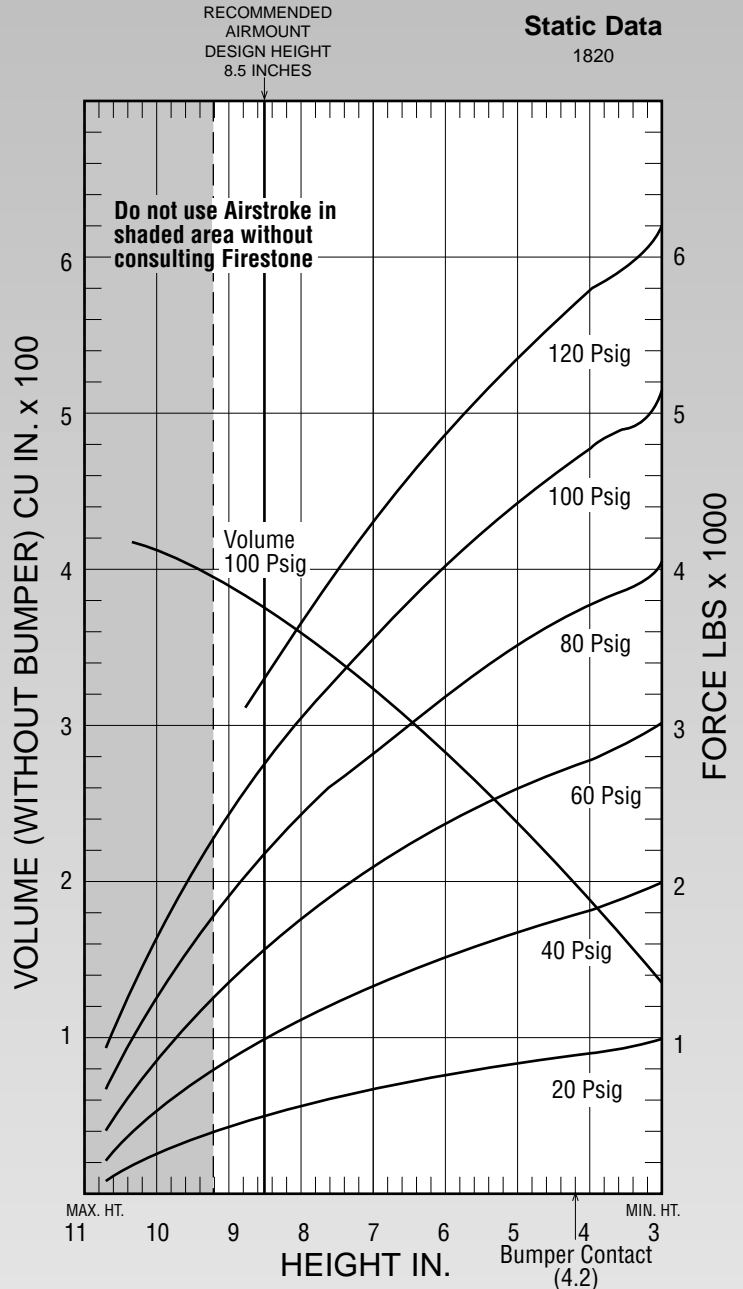

See page 12 for instructions on how to use chart.

Force Table (Use for Airstroke® actuator design)						
Assembly Height (in.)	Volume @ 100 PSIG (in <sup>3</sup> )	Pounds Force				
		@20 PSIG	@40 PSIG	@60 PSIG	@80 PSIG	@100 PSIG
9.0	390	420	850	1,330	1,850	2,380
8.0	360	550	1,120	1,730	2,390	3,030
7.0	325	660	1,330	2,090	2,830	3,570
6.0	284	760	1,520	2,390	3,180	4,030
5.0	239	840	1,680	2,610	3,510	4,430
4.0	190	920	1,830	2,810	3,790	4,790