

1T15M-9 Firestone



Description		Assembly Order No.
Style 1T15M-9	Blind nuts, 1/4 NPT	WO1-358-9108
	Blind nuts, 1/4 NPT, bumper	WO1-358-9104
Two Ply Bellows	Blind nuts, 3/4 NPT	WO1-358-9106
	Blind nuts, 3/4 NPT, bumper	WO1-358-9117
Assembly weight		18.0 lbs.

CONSULT FIRESTONE BEFORE USING AS AIRMOUNT

RECOMMENDED AIRMOUNT DESIGN HEIGHT 18.5 INCHES

Static Data 3797

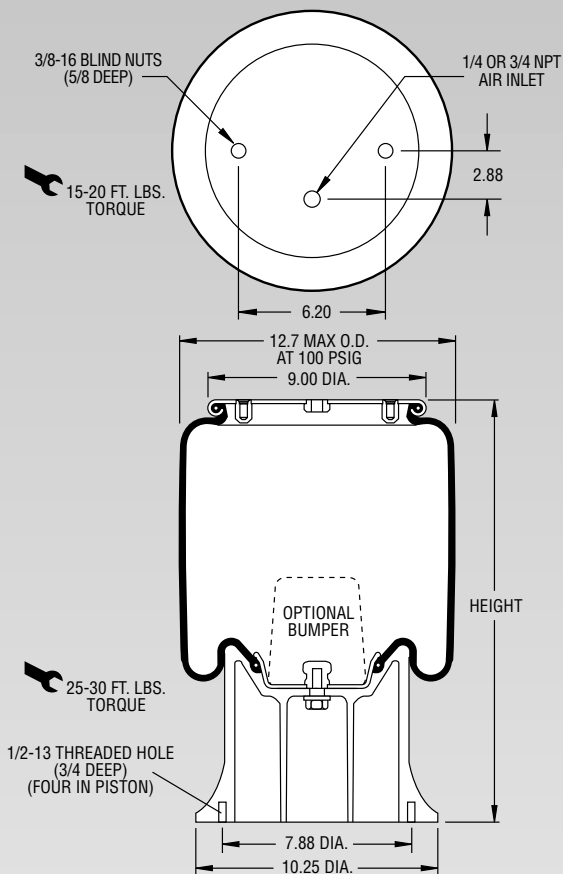

NOTE: Bellows will not compress properly with less than 10 PSIG internal pressure.

NOTE: A bead plate part is shown. This part is also available with a bead ring. Bolts are not included. See pages 8-10 for explanation.

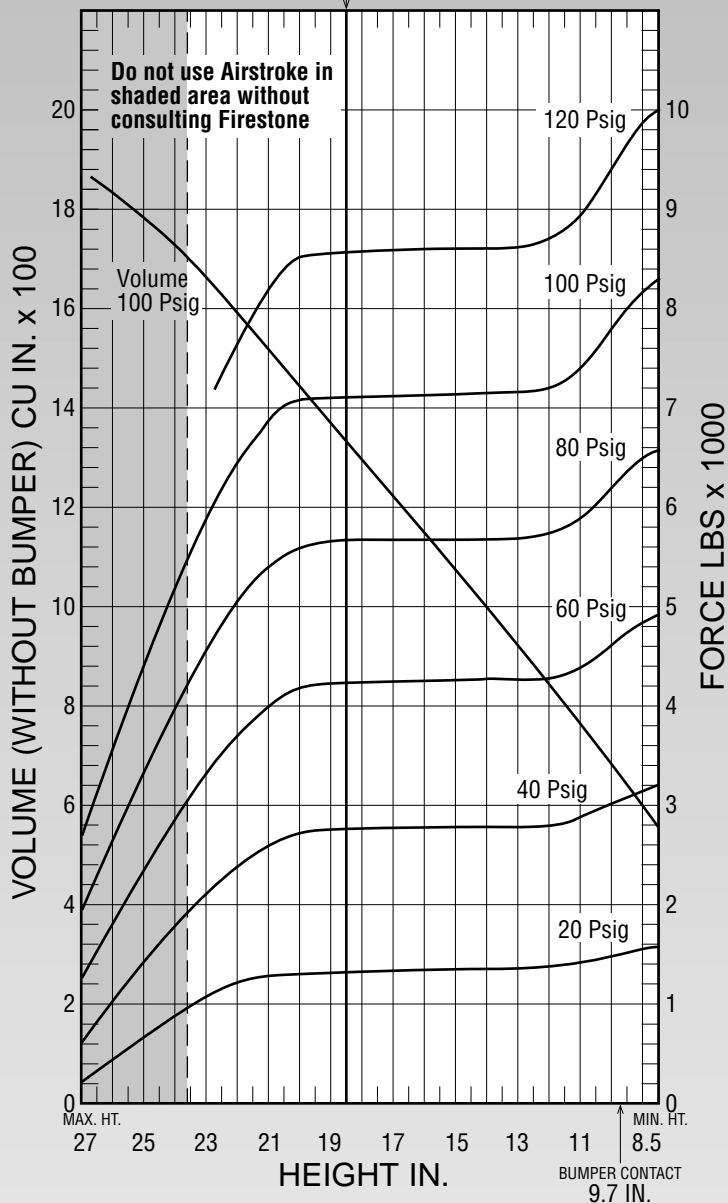

See page 12 for instructions on how to use chart.

Dynamic Characteristics at 18.5 in. Design Height (Required for Airmount isolator design only)				
Volume @ 100 PSIG = 1,330 in ³			Natural Frequency	
Gage Pressure (PSIG)	Load (lbs.)	Spring Rate (lbs./in.)	CPM	HZ
40	2,780	287	60	1.01
60	4,250	425	59	.99
80	5,680	546	58	.97
100	7,120	659	57	.95

Force Table (Use for Airstroke® actuator design)						
Assembly Height (in.)	Volume @ 100 PSIG (in ³)	Pounds Force				
		@20 PSIG	@40 PSIG	@60 PSIG	@80 PSIG	@100 PSIG
23.0	1,658	1,090	2,150	3,340	4,560	5,850
21.0	1,517	1,290	2,600	4,020	5,380	6,860
19.0	1,368	1,340	2,780	4,240	5,660	7,110
17.0	1,217	1,370	2,770	4,250	5,680	7,140
15.0	1,067	1,380	2,810	4,290	5,690	7,150
13.0	916	1,390	2,810	4,280	5,700	7,170
11.0	760	1,460	2,950	4,430	5,940	7,500
9.0	596	1,580	3,200	4,880	6,550	8,230