

1T15M-4 Firestone

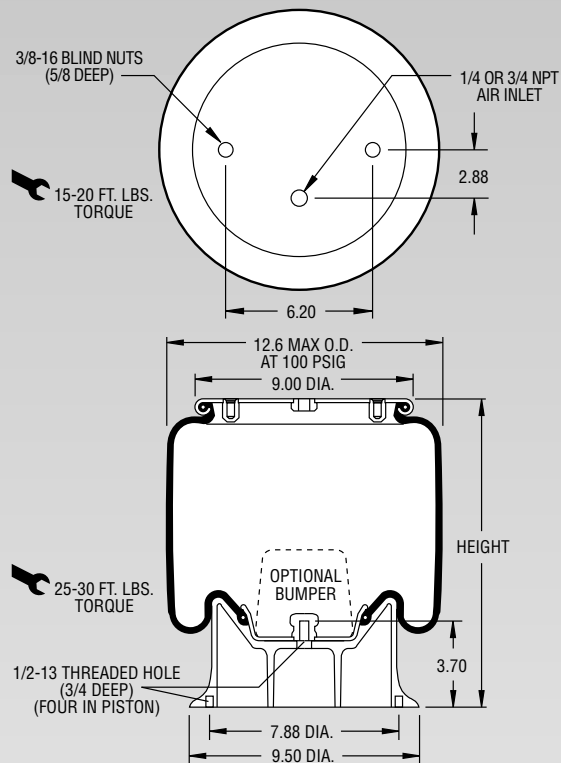

Description		Assembly Order No.
Style 1T15M-4	Blind nuts, 1/4 NPT	WO1-358-9056
	Blind nuts, 1/4 NPT, bumper	WO1-358-9057
Two Ply Bellows	Blind nuts, 3/4 NPT	WO1-358-9062
	Blind nuts, 3/4 NPT, bumper	WO1-358-9060
Assembly weight		14.3 lbs



NOTE: Bellows will not compress properly with less than 10 PSIG internal pressure.

NOTE: A bead plate part is shown. This part is also available with a bead ring. Bolts are not included. See pages 8-10 for explanation.

CONSULT FIRESTONE BEFORE USING AS AIRMOUNT

RECOMMENDED AIRMOUNT DESIGN HEIGHT 12.5 INCHES

Static Data 3068

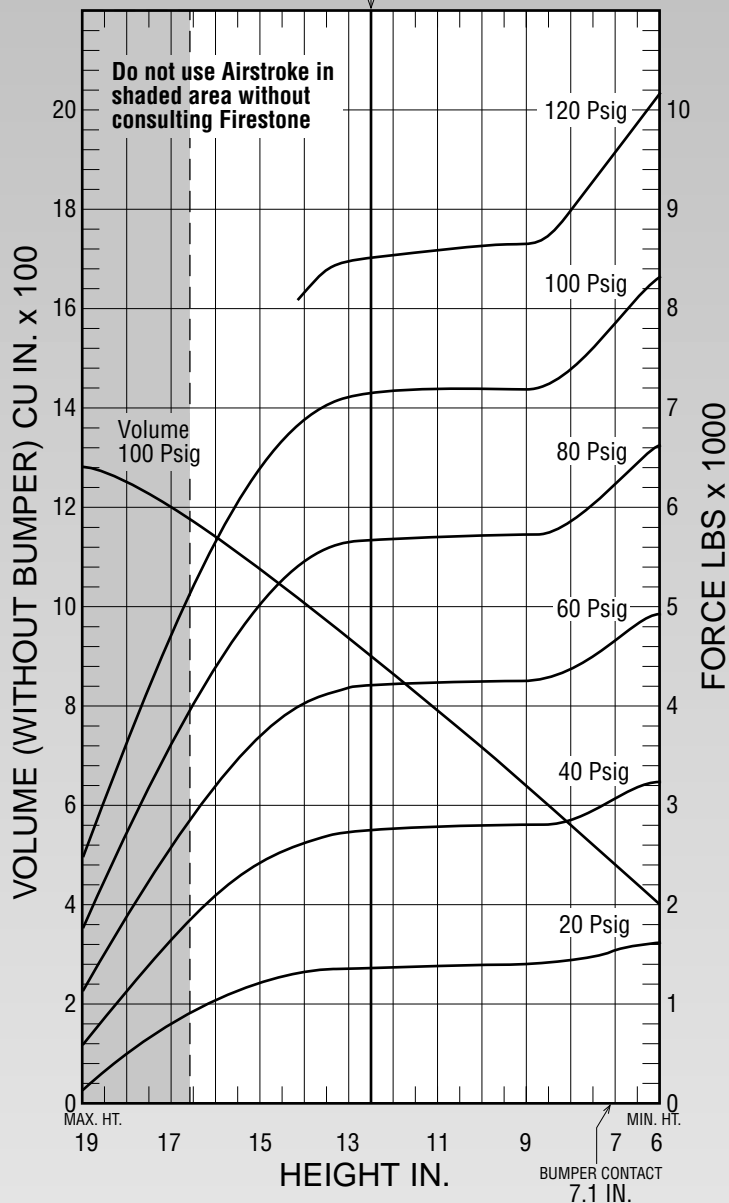

See page 12 for instructions on how to use chart.

Dynamic Characteristics at 12.5 in. Design Height (Required for Airmount isolator design only)				
Volume @ 100 PSIG = 898 in ³			Natural Frequency	
Gage Pressure (PSIG)	Load (lbs.)	Spring Rate (lbs./in.)	CPM	HZ
40	2,760	459	77	1.28
60	4,200	620	72	1.20
80	5,670	803	71	1.18
100	7,170	986	70	1.16

Force Table (Use for Airstroke® actuator design)						
Assembly Height (in.)	Volume @ 100 PSIG (in ³)	Pounds Force				
		@20 PSIG	@40 PSIG	@60 PSIG	@80 PSIG	@100 PSIG
16.0	1,146	1,060	2,110	3,240	4,410	5,680
14.0	1,010	1,330	2,650	4,050	5,460	6,910
12.0	861	1,380	2,770	4,210	5,690	7,190
10.0	711	1,390	2,790	4,230	5,720	7,190
8.0	561	1,440	2,880	4,370	5,860	7,400