

1T15M-0 Firestone

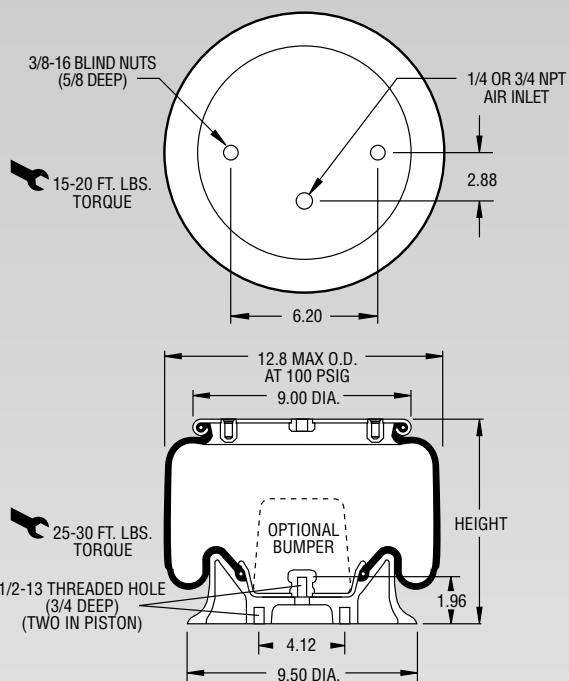

Description		Assembly Order No.
Style 1T15M-0 Two Ply Bellows	Blind nuts, 1/4 NPT	WO1-358-9030
	Blind nuts, 1/4 NPT, rubber bumper	WO1-358-9031
	Blind nuts, 3/4 NPT	WO1-358-9034
	Blind nuts, 3/4 NPT, rubber bumper	WO1-358-9036
	Countersunk steel bead ring, 1 ³ / ₈ bolts, nuts, washers	WO1-358-9038
	Integral studs, 1/4 NPT	WO1-358-9035
Assembly weight		11.5 lbs.



NOTE: Bellows will not compress properly with less than 10 PSIG internal pressure.

NOTE: A bead plate part is shown. This part is also available with a bead ring. Bolts are not included. See pages 8-10 for explanation.

CONSULT FIRESTONE BEFORE USING AS AIRMOUNT

RECOMMENDED AIRMOUNT DESIGN HEIGHT 7.5 INCHES

Static Data 8826

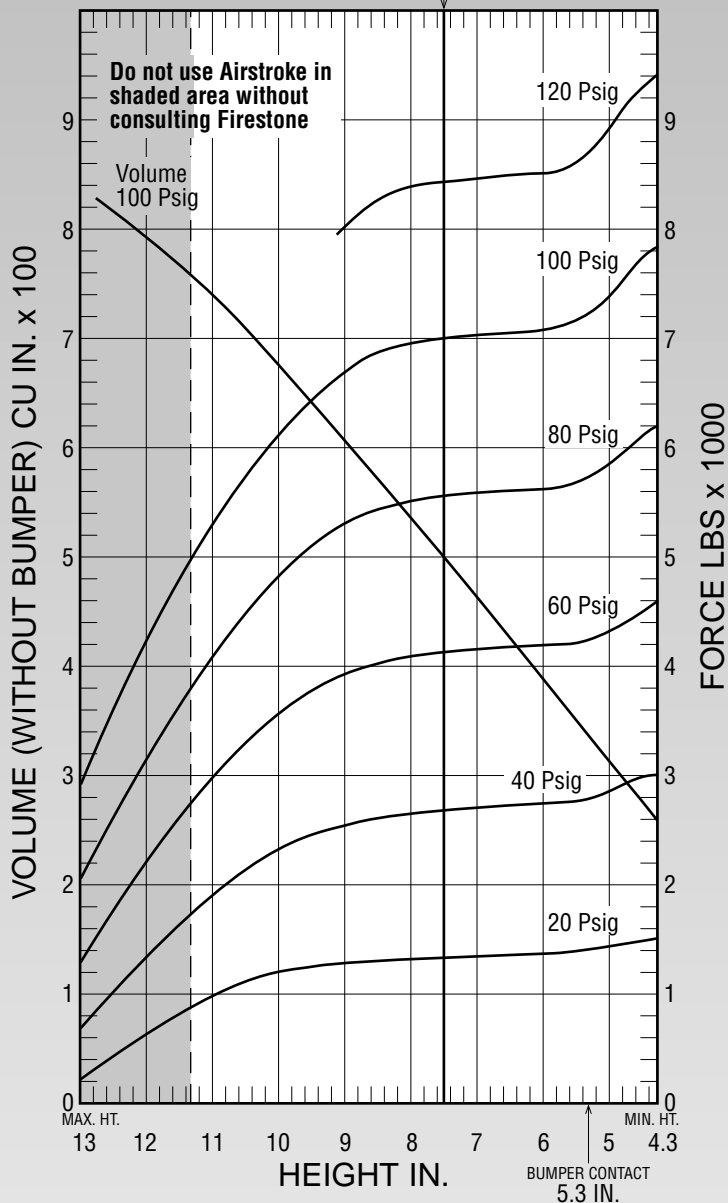

See page 12 for instructions on how to use chart.

Dynamic Characteristics at 7.5 in. Design Height (Required for Airmount isolator design only)				
Volume @ 100 PSIG = 498 in ³			Natural Frequency	
Gage Pressure (PSIG)	Load (lbs.)	Spring Rate (lbs./in.)	CPM	HZ
40	2,670	793	102	1.71
60	4,120	1,105	97	1.62
80	5,540	1,399	94	1.57
100	6,990	1,690	92	1.54

Force Table (Use for Airstroke® actuator design)						
Assembly Height (in.)	Volume @ 100 PSIG (in ³)	Pounds Force				
		@20 PSIG	@40 PSIG	@60 PSIG	@80 PSIG	@100 PSIG
11.0	737	980	1,920	2,980	4,120	5,300
10.0	675	1,180	2,310	3,550	4,810	6,130
9.0	606	1,270	2,540	3,910	5,290	6,710
8.0	534	1,300	2,630	4,080	5,500	6,950
7.0	462	1,320	2,690	4,140	5,570	7,010
6.0	389	1,350	2,730	4,170	5,610	7,070
5.0	314	1,410	2,840	4,310	5,840	7,370