

1T14C-7 Firestone

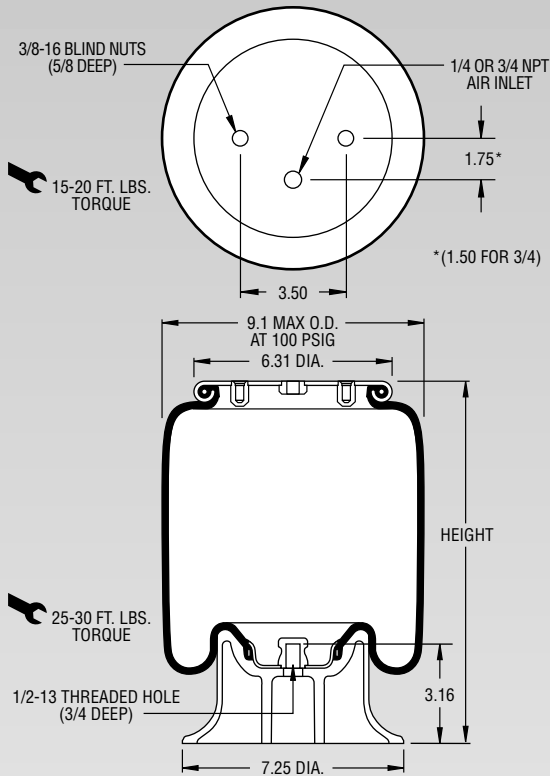

Description		Assembly Order No.
Style 1T14C-7	Blind nuts, 1/4 NPT	WO1-358-5712
Two Ply Bellows	Blind nuts, 3/4 NPT	WO1-358-5708
Assembly weight 7.0 lbs.		
Style 1T28C-7	Blind nuts, 1/4 NPT	WO1-358-5743
High Strength Bellows		



NOTE: Bellows will not compress properly with less than 10 PSIG internal pressure.

NOTE: A bead plate part is shown. This part is also available with a bead ring. Bolts are not included. See pages 8-10 for explanation.

Dynamic Characteristics at 13.5 in. Design Height (Required for Airmount isolator design only)				
Volume @ 100 PSIG = 507 in ³			Natural Frequency	
Gage Pressure (PSIG)	Load (lbs.)	Spring Rate (lbs./in.)	CPM	HZ
40	1,250	166	68	1.14
60	1,910	243	67	1.12
80	2,600	305	64	1.07
100	3,240	397	66	1.10

CONSULT FIRESTONE BEFORE USING AS AIRMOUNT

RECOMMENDED AIRMOUNT DESIGN HEIGHT 13.5 INCHES

Static Data 3045

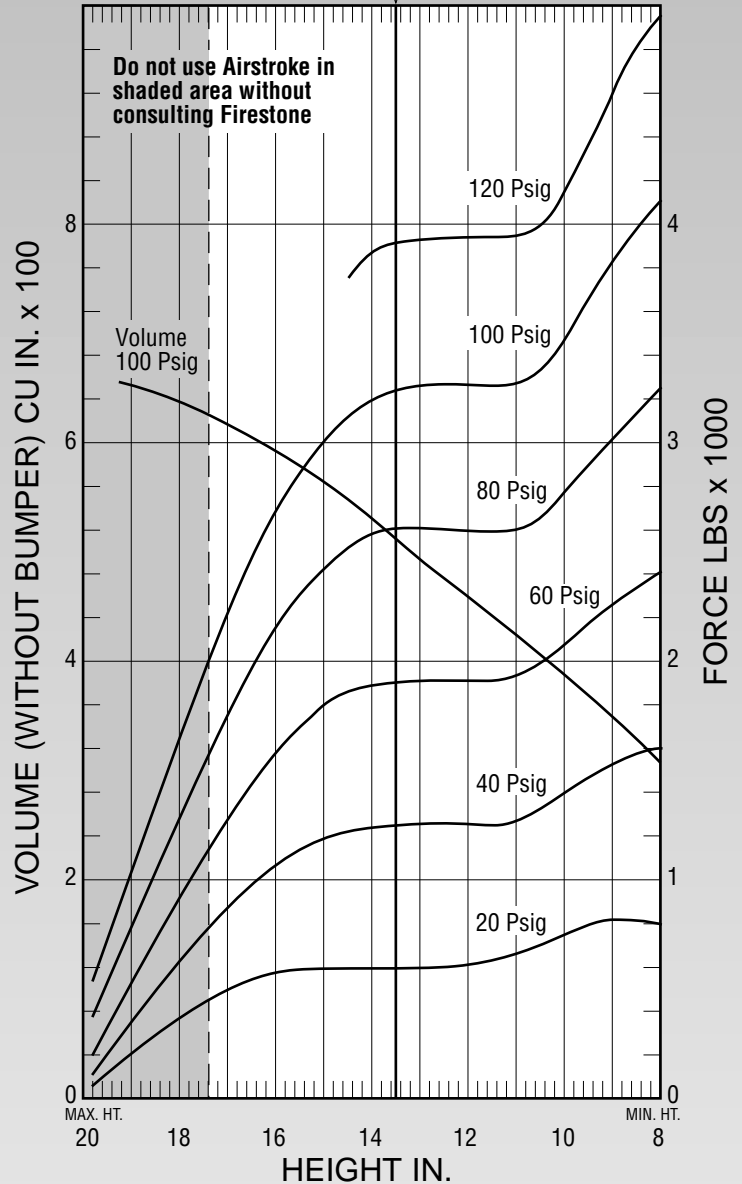

See page 12 for instructions on how to use chart.

Force Table (Use for Airstroke® actuator design)						
Assembly Height (in.)	Volume @ 100 PSIG (in ³)	Pounds Force				
		@20 PSIG	@40 PSIG	@60 PSIG	@80 PSIG	@100 PSIG
17.0	615	500	890	1,310	1,790	2,260
15.0	558	600	1,210	1,820	2,460	3,070
13.0	490	600	1,250	1,920	2,610	3,260
11.0	421	660	1,280	1,930	2,610	3,270
9.0	349	820	1,540	2,270	3,040	3,850