

Description		Assembly Order No.
Style 1T14C-3	Blind nuts, 1/4 NPT	WO1-358-5405
Two Ply Bellows		
Assembly weight		6.8 lbs.

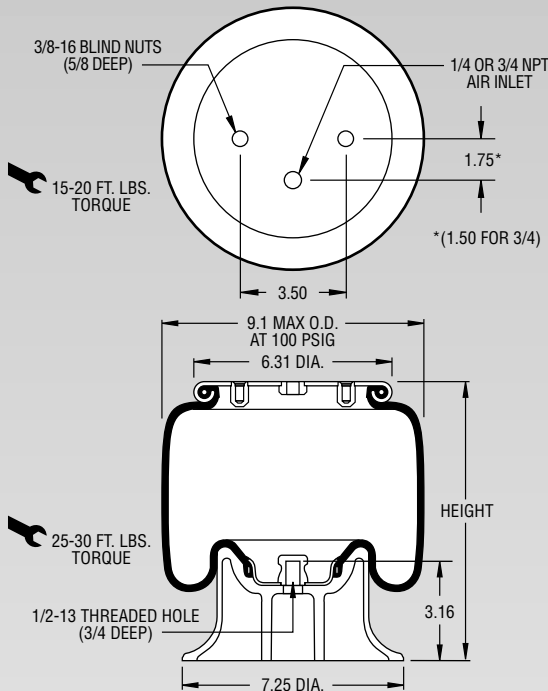

NOTE: Bellows will not compress properly with less than 10 PSIG internal pressure.

NOTE: A bead plate part is shown. This part is also available with a bead ring. Bolts are not included. See pages 8-10 for explanation.

Dynamic Characteristics at 11.0 in. Design Height (Required for Airmount isolator design only)				
Volume @ 100 PSIG = 366 in ³			Natural Frequency	
Gage Pressure (PSIG)	Load (lbs.)	Spring Rate (lbs./in.)	CPM	HZ
40	1,230	214	78	1.31
60	1,890	333	79	1.31
80	2,570	424	76	1.27
100	3,240	520	75	1.25

CONSULT FIRESTONE BEFORE USING AS AIRMOUNT

RECOMMENDED AIRMOUNT DESIGN HEIGHT 11.0 INCHES

Static Data 3018

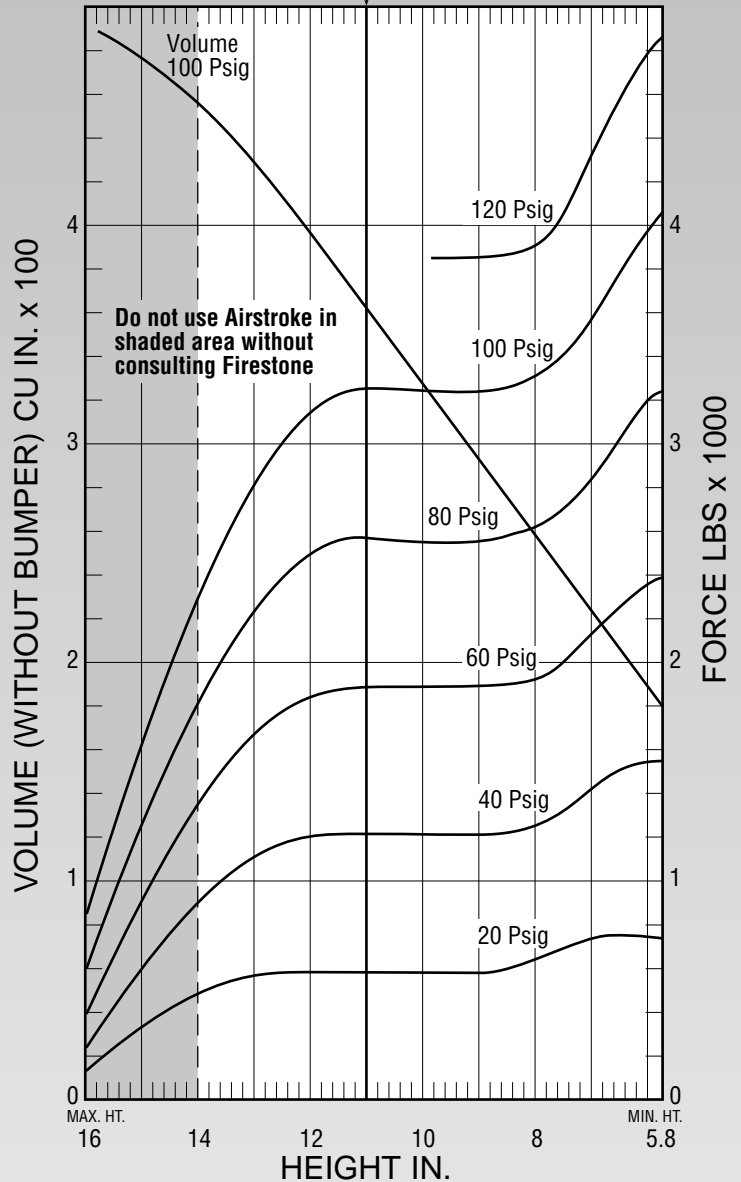

See page 12 for instructions on how to use chart.

Force Table (Use for Airstroke® actuator design)						
Assembly Height (in.)	Volume @ 100 PSIG (in ³)	Pounds Force				
		@20 PSIG	@40 PSIG	@60 PSIG	@80 PSIG	@100 PSIG
14.0	456	490	890	1,330	1,780	2,240
12.0	399	590	1,210	1,840	2,470	3,130
10.0	331	590	1,220	1,900	2,560	3,240
8.0	263	650	1,260	1,940	2,630	3,310
6.0	189	760	1,570	2,370	3,200	4,010