

1T14C-1 Firestone



Description		Assembly Order No.
Style 1T14C-1	Blind nuts, 1/4 NPT	WO1-358-5310
	Blind nuts, 1/4 NPT, bumper	WO1-358-5311
Two Ply Bellows	Blind nuts, 3/4 NPT	WO1-358-5305
	Blind nuts, 3/4 NPT, bumper	WO1-358-5306
	Countersunk steel bead ring 1 3/4 bolts, nuts, washers	WO1-358-5307
Assembly weight		6.5 lbs.

CONSULT FIRESTONE BEFORE USING AS AIRMOUNT

RECOMMENDED AIRMOUNT DESIGN HEIGHT 10.0 INCHES

Static Data 3019

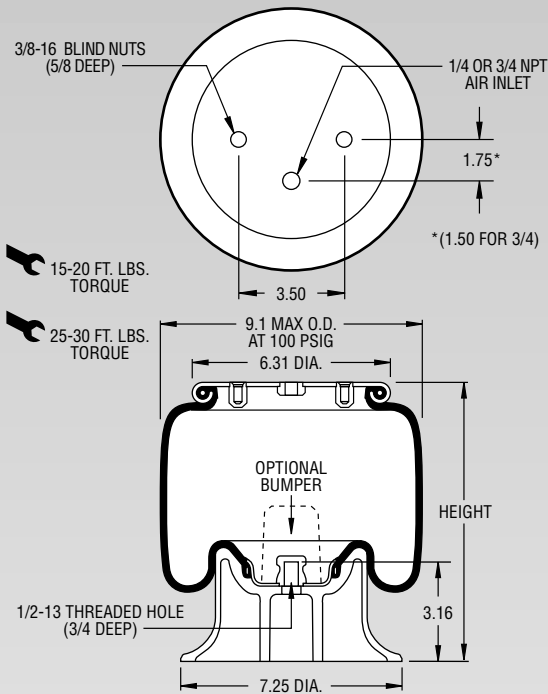

NOTE: Bellows will not compress properly with less than 10 PSIG internal pressure.

NOTE: A bead plate part is shown. This part is also available with a bead ring. Bolts are not included. See pages 8-10 for explanation.

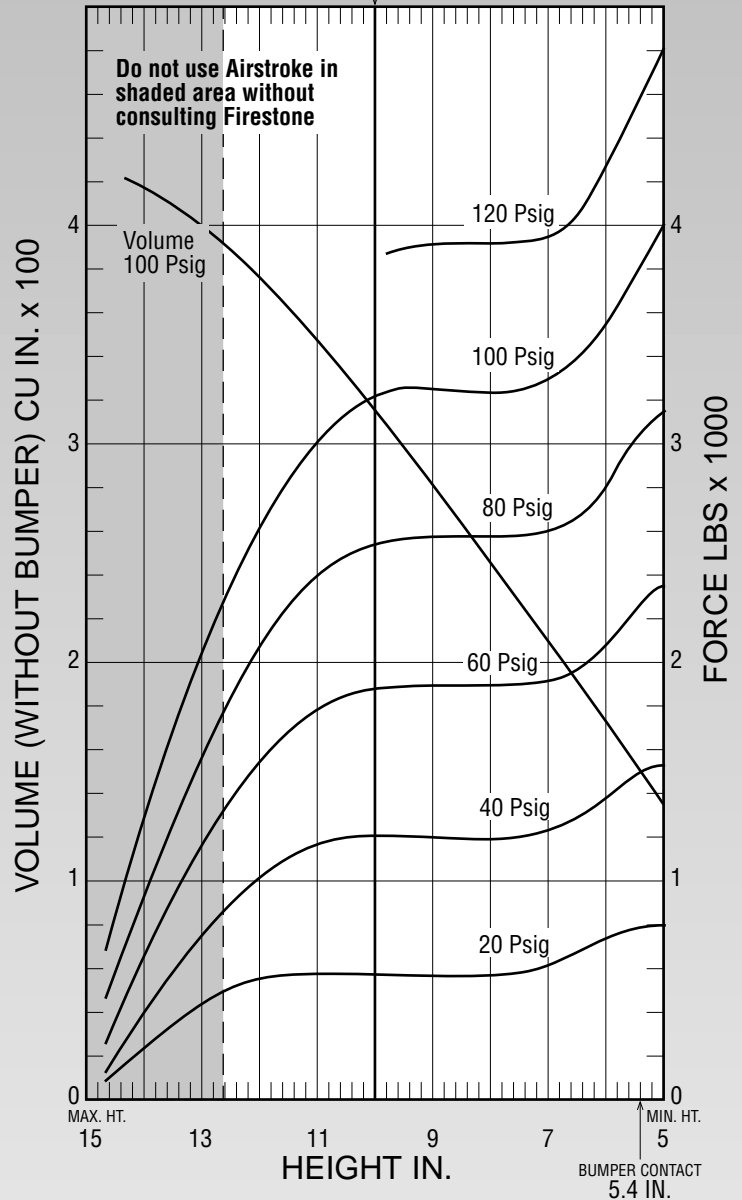

See page 12 for instructions on how to use chart.

Dynamic Characteristics at 10.0 in. Design Height (Required for Airmount isolator design only)				
Volume @ 100 PSIG = 314 in ³			Natural Frequency	
Gage Pressure (PSIG)	Load (lbs.)	Spring Rate (lbs./in.)	CPM	HZ
40	1,210	250	85	1.42
60	1,880	398	86	1.44
80	2,540	535	86	1.43
100	3,220	658	85	1.41

Force Table (Use for Airstroke® actuator design)						
Assembly Height (in.)	Volume @ 100 PSIG (in ³)	Pounds Force				
		@20 PSIG	@40 PSIG	@60 PSIG	@80 PSIG	@100 PSIG
12.0	376	540	1,010	1,530	2,040	2,600
11.0	347	570	1,160	1,770	2,380	3,010
10.0	314	590	1,210	1,880	2,540	3,220
9.0	280	590	1,190	1,890	2,570	3,240
8.0	246	580	1,200	1,890	2,570	3,240
7.0	211	620	1,240	1,920	2,600	3,300
6.0	176	740	1,380	2,060	2,790	3,530