

Description		Assembly Order No.
Style 138-1.5	Ribbed neck aluminum bead rings (equal spacing), 1 7/8 bolts, nuts, washers	WO1-358-7737
Two Ply High Strength Bellows	Rubber bellows only	WO1-358-0147
Assembly weight .....		24.5 lbs.
Force to collapse to minimum height (@ 0 PSIG)....		150 lbs.

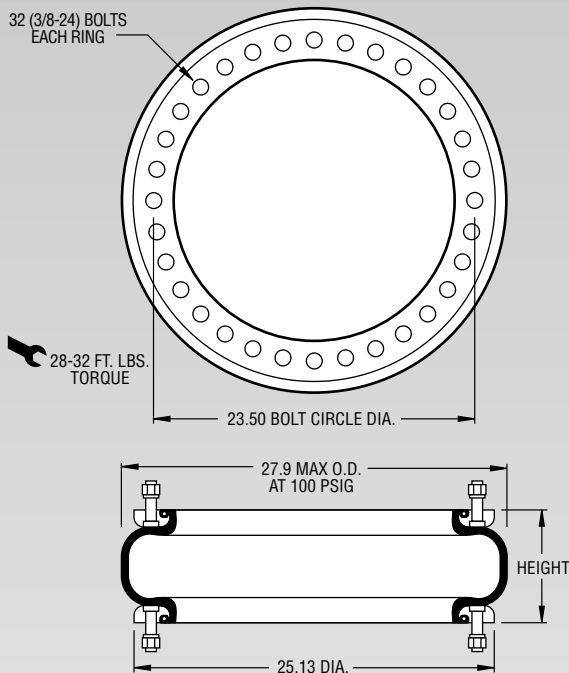

**NOTE:** A bead ring part is shown. This part is also available with rolled plates. See page 11 for explanation.

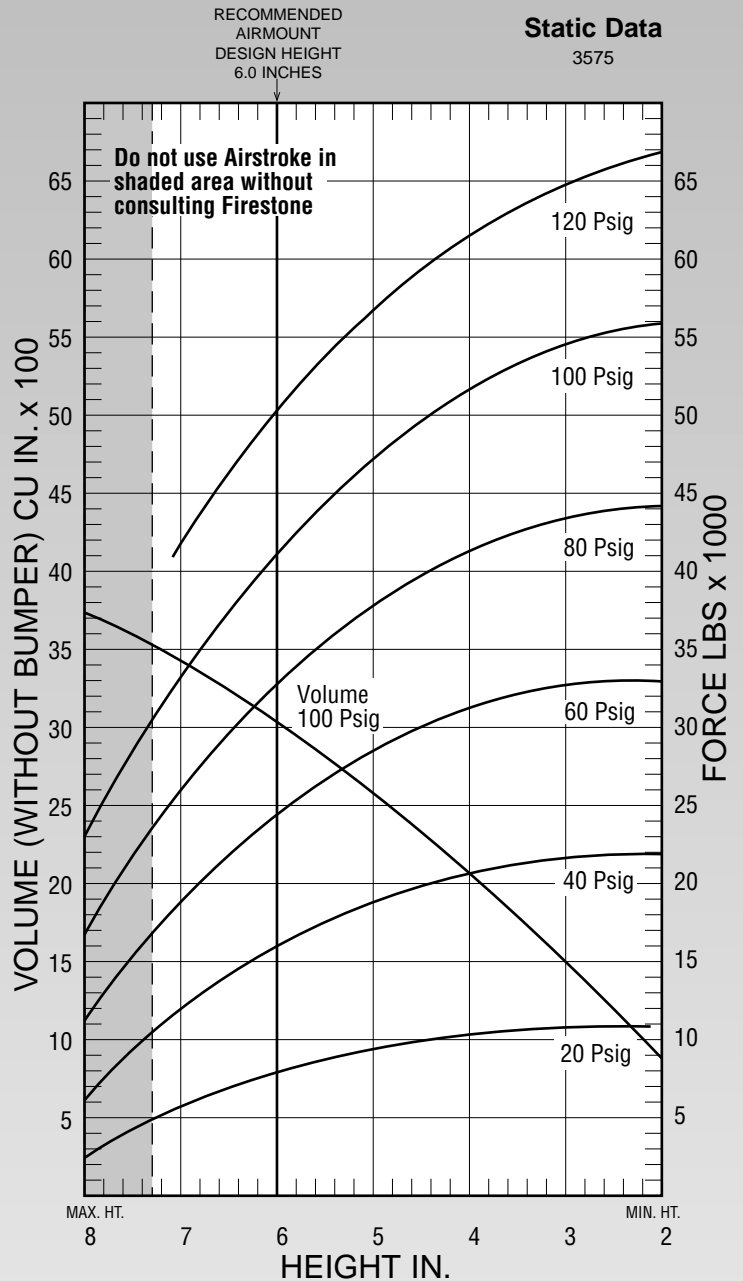

See page 12 for instructions on how to use chart.

Dynamic Characteristics at 6.0 in. Design Height (Required for Airmount isolator design only)				
Volume @ 100 PSIG = 3,014 in <sup>3</sup>			Natural Frequency	
Gage Pressure (PSIG)	Load (lbs.)	Spring Rate (lbs./in.)	CPM	HZ
40	15,870	8,190	135	2.25
60	24,490	11,439	128	2.14
80	32,890	14,427	124	2.07
100	41,620	17,301	121	2.02

Force Table (Use for Airstroke® actuator design)						
Assembly Height (in.)	Volume @ 100 PSIG (in <sup>3</sup> )	Pounds Force				
		@20 PSIG	@40 PSIG	@60 PSIG	@80 PSIG	@100 PSIG
9.0	3,419	5,390	11,420	18,340	25,320	32,820
8.0	3,014	7,770	15,870	24,490	32,890	41,620
7.0	2,552	9,410	18,910	28,740	38,230	47,890
6.0	2,045	10,360	20,670	31,280	41,520	51,850
5.0	1,509	10,860	21,560	32,660	43,430	54,250