

Description		Assembly Order No.
Style 113-1	Blind nuts, 1/4 NPT	WO1-358-7091
	Blind nuts, 3/4 NPT	WO1-358-7092
Two Ply Bellows	Blind nuts, 3/4 NPT, rubber bumper	WO1-358-7094
	Button head steel bead rings, 17/8 bolts, nuts, washers	WO1-358-7277
	Rubber bellows only	WO1-358-0150
Assembly weight .....		15.2 lbs.
Force to collapse to minimum height (@ 0 PSIG).....		25 lbs.

Style 128-1	Blind nuts, 3/4 NPT	WO1-358-8160
High Strength Bellows		

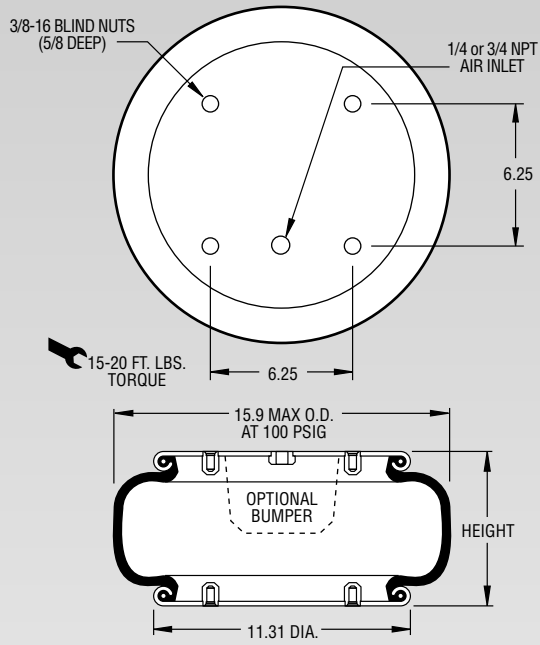

**NOTE:** A bead plate part is shown. This part is also available with bead rings. See pages 8-10 for explanation.

Dynamic Characteristics at 5.5 in. Design Height (Required for Airmount isolator design only)				
Volume @ 100 PSIG = 641 in <sup>3</sup>			Natural Frequency	
Gage Pressure (PSIG)	Load (lbs.)	Spring Rate (lbs./in.)	CPM	HZ
40	3,820	2,198	142	2.37
60	5,900	3,091	136	2.26
80	7,990	3,986	133	2.21
100	10,200	4,923	130	2.17

RECOMMENDED AIRMOUNT DESIGN HEIGHT 5.5 INCHES

**Static Data**  
A8915

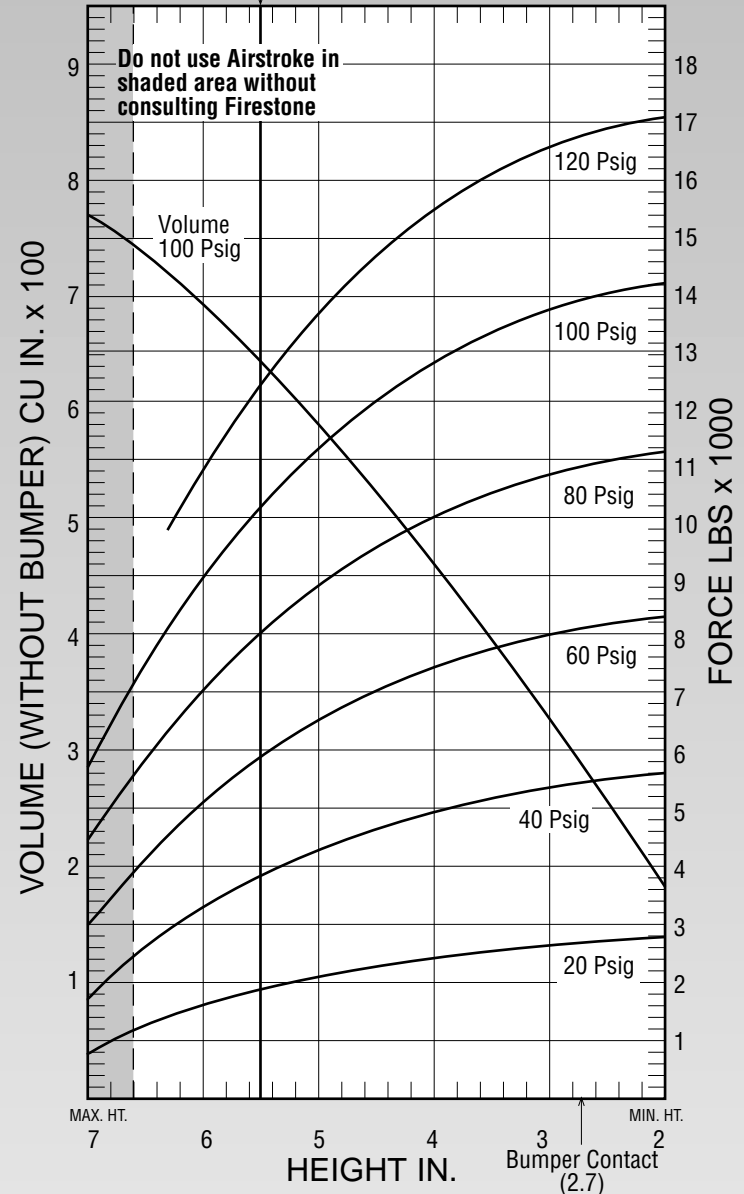

See page 12 for instructions on how to use chart.

Force Table (Use for Airstroke <sup>®</sup> actuator design)						
Assembly Height (in.)	Volume @ 100 PSIG (in <sup>3</sup> )	Pounds Force				
		@20 PSIG	@40 PSIG	@60 PSIG	@80 PSIG	@100 PSIG
6.0	692	1,600	3,270	5,130	7,000	8,990
5.0	586	2,070	4,260	6,530	8,800	11,200
4.0	463	2,440	4,940	7,470	10,080	12,710
3.0	328	2,660	5,360	8,060	10,860	13,630