

Description		Assembly Order No.
Style 113	Blind nuts, 1/4 NPT	WO1-358-7103
	Blind nuts, 1/4 NPT, bumper	WO1-358-7104
Two Ply Bellows	Blind nuts, 3/4 NPT	WO1-358-7101
	Blind nuts, 3/4 NPT, bumper	WO1-358-7109
	Button head steel bead rings, 1 7/8 bolts, nuts, washers	WO1-358-7110
	Blind nuts, 1/8 NPT	WO1-753-7113
	Blind nuts, 1 1/4 NPT	WO1-753-7114
	Rubber bellows only	WO1-358-0135

Assembly weight ..... 14.5 lbs.

Force to collapse to minimum height (@ 0 PSIG)..... 17 lbs.

Style 128	Blind nuts, 1/4 NPT	WO1-358-8151
	Blind nuts, 1/4 NPT, rubber bumper	WO1-358-8149
High Strength Bellows	Blind nuts, 3/4 NPT	WO1-358-8152
	Blind nuts, 3/4 NPT, rubber bumper	WO1-358-8150
	Rubber bellows only	WO1-358-0231

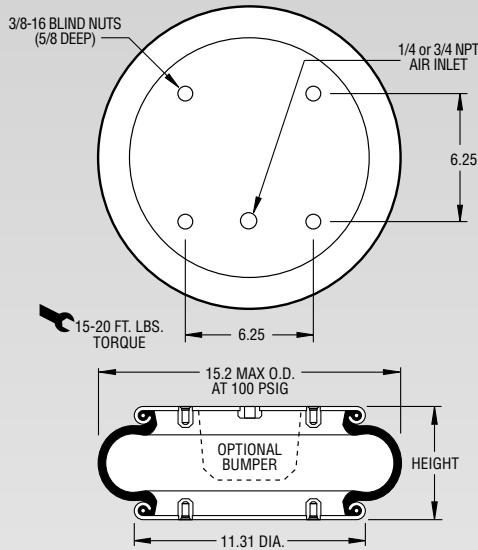

**NOTE:** A bead plate part is shown. This part is also available with bead rings. See pages 8-10 for explanation.

Dynamic Characteristics at 5.0 in. Design Height (Required for Airmount isolator design only)				
Volume @ 100 PSIG = 585 in <sup>3</sup>			Natural Frequency	
Gage Pressure (PSIG)	Load (lbs.)	Spring Rate (lbs./in.)	CPM	HZ
40	3,220	2,429	163	2.72
60	5,030	3,432	155	2.58
80	6,890	4,407	150	2.50
100	8,800	5,385	147	2.45

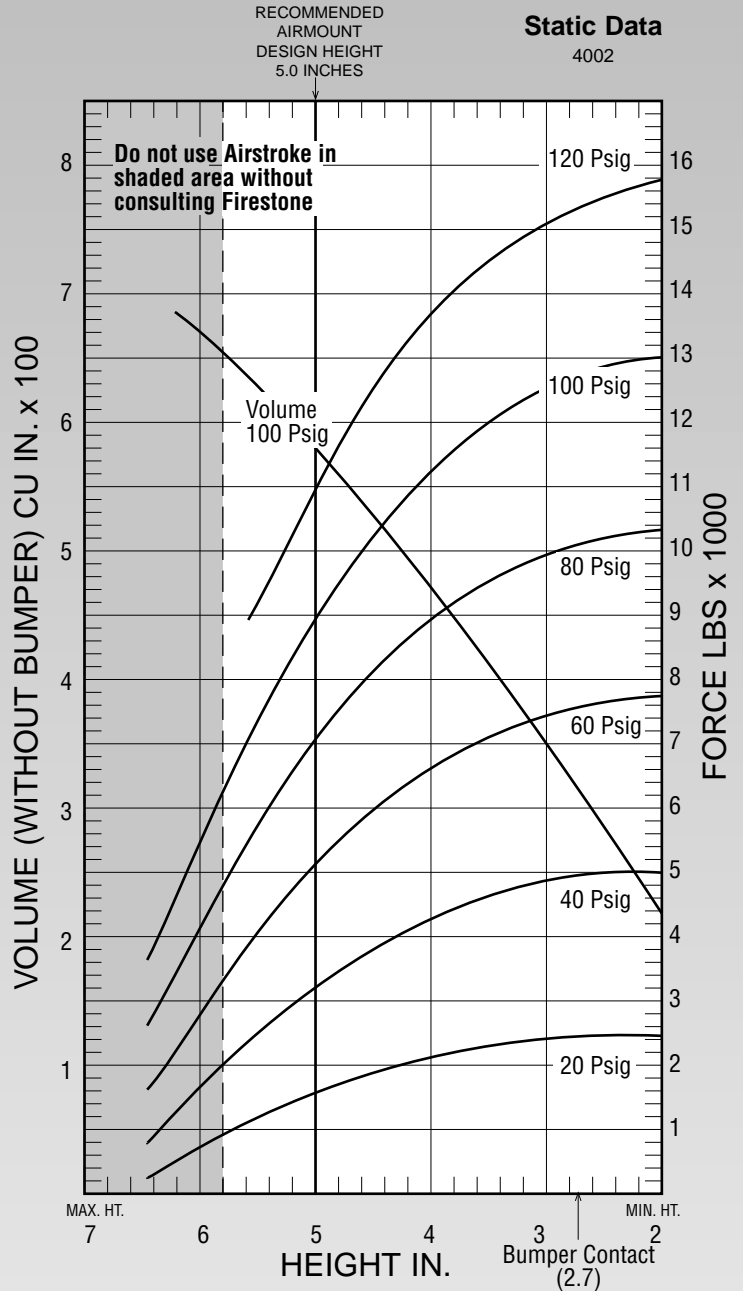

See page 12 for instructions on how to use chart.

Force Table (Use for Airstroke® actuator design)						
Assembly Height (in.)	Volume @ 100 PSIG (in <sup>3</sup> )	Pounds Force				
		@20 PSIG	@40 PSIG	@60 PSIG	@80 PSIG	@100 PSIG
5.0	585	1,540	3,220	5,030	6,890	8,800
4.0	477	2,120	4,320	6,600	8,890	11,230
3.0	353	2,390	4,830	7,380	9,900	12,470