



AIRSTROKE[®]

ACTUATORS

AIRMOUNT[®]

ISOLATORS



Firestone

World's Number 1 
Air Spring.

FIRESTONE INDUSTRIAL PRODUCTS COMPANY

Firestone

AIRSTROKE[®]

ACTUATORS

AIRMOUNT[®]

ISOLATORS

The first successful application of airsprings for vibration isolation occurred during the late nineteen thirties. Airsprings were developed by Firestone to fill a need for a more efficient suspension system for highway trucks, trailers, and buses. Airide[®] springs, as they were named, provided the means for a suspension that reduced the amount of road shock and vibration transmitted into the vehicle. Billions of miles of actual use have proven the dependability and effectiveness of the air suspension concept using Airide springs by Firestone.

Airmount isolators and Airstroke actuators are a further application and refinement of the Airide spring. They are basically the same product with the use of the product determining which name is applied to it. Some parts, however, are designed for a particular application,



and all parts are not necessarily compatible with all three applications.

Airsprings are highly engineered elastomeric bellows with specially designed metal end closures.

The bellows itself is constructed from plies of cord-reinforced rubber with standard construction utilizing two plies of special cord fabric. High strength versions designed to handle greater loads and pressures are also available on many of the styles. Airmount isolators and Airstroke actuators are capable of handling loads up to 100,000 pounds and can be designed into systems to

utilize up to fourteen inches of stroke.

The standard air-spring will operate in temperatures from -35°F to 135°F and special compounds are available on some parts to extend this range.

TYPICAL APPLICATIONS

AIRSTROKE ACTUATORS

Airstroke actuators are used primarily in place of pneumatic or hydraulic cylinders. A few of the typical applications currently include:

- Surface area presses
- Stamping presses
- Conveyors
- Clamping devices
- Assembly equipment
- Irrigation equipment
- Automotive alignment equipment
- Paper and textile machinery
- Sawmill machinery
- Material handling
- Valves
- Commercial laundry

Due to the unique capabilities of Airstroke and Airmount products, many applications are in use where the product is used for both actuation and isolation, or for a completely different purpose. Just a few of these applications include:

- Protective boots
- Flexible connectors
- Vacuum devices
- Shock absorbers
- Expansion chambers
- Drive couplings

AIRMOUNT ISOLATORS

Airmount isolators are used as vibration isolators on many different types of equipment. Following is a partial list of just a few of the typical types of installations.

Lasers	Fans
Holographs	Anechoic chambers
Electron microscopes	Vibrating screens and sifters
Optical benches	Earthquake simulator
Spectrometers	Vibrating conveyors and feeders
Interferometers	Inertial mass mountings
Test bed shakers	Vibrating test equipment
Shock test equipment	Seat springs
Forging hammers	
Generator sets	
Industrial machinery	

Firestone Selection Guide

END CLOSURE OPTIONS

Style Number	Maximum Diameter at 100 PSIG (inches)	High Strength Number
--------------	---------------------------------------	----------------------

SHAPED SLEEVE

1M1A-0	3.4	
1M1A-1	3.45	
2M1A	3.5	
2M2A	2.3	

SINGLE CONVOLUTION

16	6.0	
16ST	5.4	
131	6.5	
110	8.3	
116	9.1	117
116-1	9.6	
115	10.1	124
19	12.9	
19-.75	13.5	
113	15.2	128
113-1	15.9	128-1
153-2	18.1	
119**	17.4	
121**	20.3	
126**	22.4	
138-1.5	27.9	
148-1	37.4	148-1 is 4Ply

DOUBLE CONVOLUTION

25	6.4	
255-1.5	6.5	
224	8.0	
26	8.6	
20	9.9	202
20-2	10.4	
22	12.9	210
22-1.5	13.7	
21	15.1	205
21-2	16.0	
233-2	15.5	
28**	17.4	201
203**	20.0	218
29**	22.7	207
200	26.0	
215	27.9	
248-2	37.4	248-2 is 4Ply

TRIPLE CONVOLUTION

352	13.1	
313	15.1	39
333	15.2	
312**	18.2	314
323**	20.5	324
320**	22.4	328
321	27.9	
348-3	37.4	348-3 is 4Ply

REVERSIBLE SLEEVE

1X84D-1	NOT AN AIRSTROKE ACTUATOR	
4001	3.1	
7002	4.2	
7010	4.0	
7012	5.0	
1T12E-3	5.0	
1T14C-1	9.1	
1T14C-3	9.0	
1T14C-7	9.0	1T28C-7
1T15T-1	11.2	
1T15S-6	11.1	
1T15L-4	11.7	
1T15M-0	12.8	
1T15M-2	12.6	
1T15M-4	12.6	
1T15M-6	12.6	
1T15M-9	12.7	
1T19L-7	14.2	
1T19L-11	14.2	

Bead Plate Type	Dim. A (blind nut centers) (inches)	Dim. B (inches)	Bead Ring Type	Dim. C (bolt circle diameter) (inches)	Number of Bolts (each ring)
-----------------	-------------------------------------	-----------------	----------------	--	-----------------------------

SEE INDIVIDUAL DATA PAGE

1	1.75		4	4.50	6
1	1.75		N/A	N/A	N/A
1	1.75		4	4.50	6
1	1.75		4	4.50	6
1	2.75		4	5.31	6
1	2.75		4	5.31	6
3	3.50	1.75*	4	6.31	8
3	6.20	2.88	4	9.00	12
3	6.20	2.88	4	9.00	12
2	6.25		4	11.31	12
2	6.25		4	11.31	12
2	6.25		N/A	N/A	N/A
5	9.00	13.79	4	13.81	18
5	12.00	16.50	4	16.50	24
5	15.00	19.00	4	19.00	24
			4	23.50	32
			4	32.68	40

1	1.75		4	4.50	6
1	1.75		4	4.50	6
1	2.75		4	5.31	6
1	2.75		4	5.31	6
3	3.50	1.75*	4	6.31	8
3	3.50	1.75	4	6.31	8
3	6.20	2.88	4	9.00	12
3	6.20	2.88	4	9.00	12
2	6.25		4	11.31	12
2	6.25		4	11.31	12
2	6.25		4	11.31	12
5	9.00	13.79	4	13.81	18
5	12.00	16.50	4	16.50	24
5	15.00	19.00	4	19.00	24
			4	22.00	24
			4	23.50	32
			4	32.68	40

3	6.20	2.88	N/A	N/A	N/A
2	6.25		4	11.31	12
2	6.25		4	11.31	12
5	9.00	13.79	4	13.81	18
5	12.00	16.50	4	16.50	24
5	15.00	19.00	4	19.00	24
			4	23.50	32
			4	32.68	40

SEE INDIVIDUAL DATA PAGE

1	1.75		4	4.50	6
3	3.50	1.75*	4	6.31	8
3	3.50	1.75*	4	6.31	8
3	3.50	1.75*	4	6.31	8
3	6.20	2.88	4	9.00	12
3	6.20	2.88	4	9.00	12
3	6.20	2.88	4	9.00	12
3	6.20	2.88	4	9.00	12
3	6.20	2.88	4	9.00	12
3	6.20	2.88	4	9.00	12
3	6.20	2.88	4	9.00	12
3	6.20	2.88	4	9.00	12
2	6.25		4	11.31	12
2	6.25		4	11.31	12

END CLOSURES

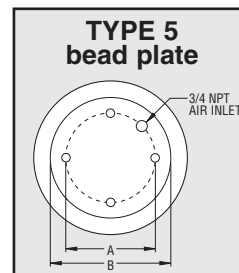
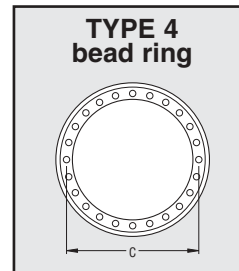
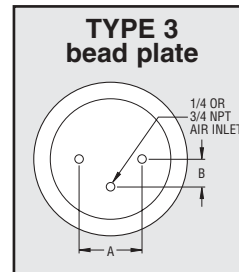
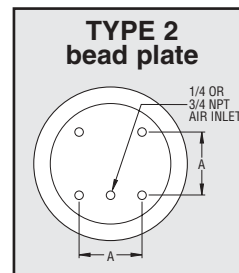
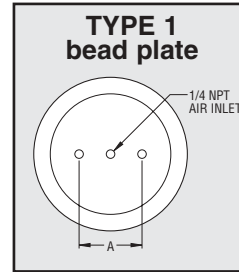

SIDE PROFILE

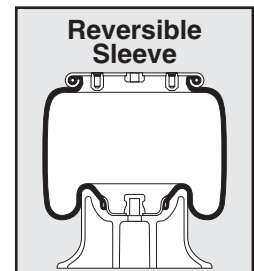
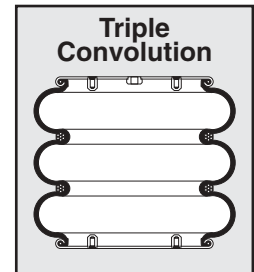
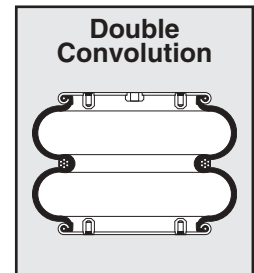
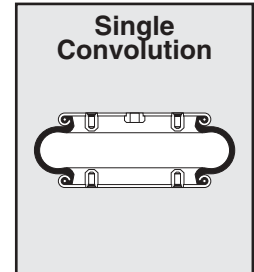

* On plates with a 3/4 inch NPT air inlet, B dimension is 1.50 inch.
 ** When using the rolled plate end closure option, add .7 inch to heights shown.

AIRSTROKE® ACTUATORS

Style Number	Minimum Height (inches)	Maximum Stroke (inches)	80 PSI Force* at Stroke of		
			1 Inch (pounds)	3 Inches (pounds)	Maximum Stroke (pounds)

SHAPED SLEEVE

1M1A-0	1.5	1.4	450		400
1M1A-1	1.5	2.0	490		375
2M1A	2.5	3.4	470	410	360
2M2A	1.2	1.0	10.8		10.8

SINGLE CONVOLUTION

16	1.9	1.4	960		620
16ST	1.8	1.5	930		580
131	2.0	2.1	1,350		850
110	2.0	3.1	2,090	1,030	940
116	2.0	3.1	2,690	1,370	1,300
116-1	2.0	4.2	2,980	2,240	1,460
115	2.0	3.1	3,550	1,730	1,620
19	2.0	3.5	6,720	4,500	3,400
19-.75	2.0	3.9	7,040	5,000	3,250
113	2.0	3.8	9,900	6,890	4,650
113-1	2.0	4.6	10,860	8,800	5,500
153-2	2.5	4.8	13,135	10,604	6,422
119**	2.0	4.2	14,030	11,450	7,850
121**	2.0	3.6	19,600	14,450	11,350
126**	2.0	4.4	25,990	22,460	16,000
138-1.5	2.0	5.3	43,430	38,230	22,700
148-1	2.5	4.8	78,300	67,690	52,500

DOUBLE CONVOLUTION

25	2.8	3.3	1,380	780	660
255-1.5	3.0	4.0	2,039	1,786	1,198
224	2.8	4.9	2,350	1,760	1,030
26	3.0	5.7	2,700	2,230	1,420
20	3.0	6.1	3,790	3,180	1,770
20-2	3.0	8.0	4,125	3,753	2,122
22	3.0	7.1	7,180	6,470	3,700
22-1.5	3.0	7.8	7,680	6,990	3,830
21	3.0	7.1	10,300	9,310	5,670
21-2	3.0	8.7	11,330	10,670	5,850
233-2	3.0	10.4	10,966	10,564	5,900
28**	3.3	6.8	15,000	13,200	8,530
203**	3.3	7.2	21,400	19,200	12,910
29**	3.3	7.5	26,900	24,400	17,280
200	3.3	7.3	35,700	33,300	24,250
215	3.3	8.8	42,500	40,000	28,160
248-2	4.2	9.1	78,200	74,100	53,990

TRIPLE CONVOLUTION

352	4.5	11.2	8,030	7,340	4,080
313	4.5	10.5	10,650	9,700	5,460
333	4.5	12.0	10,921	10,033	5,800
312**	4.5	10.4	15,700	14,200	8,740
323**	4.5	10.9	21,200	19,500	12,420
320**	4.5	11.8	28,700	26,700	17,390
321	4.5	14.2	43,300	41,200	26,420
348-3	5.5	13.8	77,000	74,000	53,600

REVERSIBLE SLEEVE

1X84D-1	DO NOT USE 1X84D-1 AS AN AIRSTROKE ACTUATOR				
4001	3.6	3.6	280	310	310
7002	3.5	2.5	710	660	660
7010	5.75	4.25	570	600	640
7012	5.0	4.5	690	750	760
1T12E-3	6.0	7.6	750	600	540
1T14C-1	5.0	7.7	2,790	2,570	1,720
1T14C-3	5.8	8.2	2,930	2,550	1,780
1T14C-7	8.0	9.4	3,040	2,610	1,630
1T15T-1	4.0	6.7	5,010	4,370	2,910
1T15S-6	6.0	10.0	5,070	4,420	2,830
1T15L-4	6.0	9.9	5,690	5,500	3,680
1T15M-0	4.3	7.0	5,700	5,550	3,840
1T15M-2	5.0	8.3	6,080	5,930	4,060
1T15M-4	6.0	10.5	6,270	5,730	4,020
1T15M-6	7.0	12.2	6,280	5,730	3,950
1T15M-9	8.5	15.1	6,450	5,850	4,210
1T19L-7	6.0	12.8	8,800	7,300	4,700
1T19L-11	8.0	15.4	8,600	7,300	5,100

* To determine Airstroke force at other pressures, divide force shown by 80 PSIG and multiply result by new pressure.

** When using the rolled plate end closure option, add .7 inch to heights shown.

Advantages of:

AIRSTROKE®

ACTUATORS

Why use an Airstroke actuator (rather than air or hydraulic cylinder) for actuation?

LOW COST

Generally, the initial cost of an Airstroke actuator is one-half or less than that of a conventional pneumatic or hydraulic cylinder of the same force capabilities. This initial cost advantage is many times greater in the larger sizes.

WIDE SIZE RANGE

Airstroke actuators are available in sizes ranging from 2.2 inches to 37 inches in diameter. The force capability is 100,000 pounds. Strokes of up to 14 inches are possible.

DURABLE FOR LONG LIFE

Airstroke actuators are another application of the proven Firestone Airide spring used on truck and bus suspensions. Airide springs have proven longevity and durability to perform under adverse environmental conditions – a critical factor in machine design.

NO MAINTENANCE OR LUBRICATION REQUIRED

Airstroke actuators have no internal rods, pistons, or sliding seals that would require lubrication or maintenance. This allows for the design of Airstroke actuators into applications where dirt or grit would destroy the seals on conventional cylinders.

FRICTION FREE FOR IMMEDIATE RESPONSE

Since Airstroke actuators have no sliding seals, there is no break-away friction as with conventional cylinders.

FLEXIBLE MEDIA

An Airstroke actuator can do its work with either a liquid or gas. (Please see page 14 in our Engineering Manual for acceptable media choices.)

ANGULAR CAPABILITY

An Airstroke actuator possesses the unique capability of stroking through an arc without a clevis. Angular motion of up to 30 degrees is possible, along with the design advantage of generally less complex linkages.

SIDE LOADING CAPABILITY

Airstroke actuators, within certain limits, are not affected by side loads as are conventional cylinders. This misalignment capability eliminates potential rod bending, scoring, and excessive seal wear common to conventional cylinders.

COMPACT STARTING HEIGHT

Airstroke actuators have a low profile compared to conventional cylinders. Our smallest Airstroke actuator (2.2 inch/dia.) collapses to just 1.2 inches in height, while our largest triple convoluted Airstroke (37 inch/dia.) will collapse to a very compact 5.5 inches.

FACTORY SEALED AND TESTED

Most Airstroke actuators feature Firestone's proven concept of crimped end plates. The crimped design allows for pre-shipment testing and quicker installation on equipment.

Airstroke® Actuator Selection Procedure

Refer to the **selection guide** on page 4 for Airstroke actuator force and stroke capabilities. This information is intended to give a general guide to part capabilities. Before selecting the correct Airstroke actuator you need to know certain attributes of your application. Once this data is known, the selection is relatively easy. For more detailed information please obtain a copy of Firestone's Engineering Manual and Design Guide.

1. STROKE:

The maximum STROKE CAPABILITY of an Airstroke actuator is the difference between the maximum useable height and the minimum height. This entire stroke, or any portion thereof, may be used. If an internal rubber bumper is required, please note that the **minimum height is increased**, and therefore, the total stroke is decreased. Once this is determined, you can choose the general style of part you would need. For strokes of less than 3 to 4 inches, the Single Convolution parts are generally the most efficient. Use the shortest style that will give you the necessary stroke for your application.

2. FORCE:

Read the forces from the chart for 100 psi at 1 inch, 50% of Maximum Stroke, and Maximum Stroke. Notice that the force

generally decreases as height increases. If you have less than 100 psi available, divide the force by 100 and multiply by your available pressure. If your stroke is between these values, a straight line interpolation will approximate the value. You should always check our Engineering Manual and Design Guide for more exact information. Select the smallest part with the necessary stroke to meet your force requirements.

3. DIMENSIONAL DATA CAN BE FOUND ON PAGE 3:

It is important to make sure that the part you select will fit in the available space. The higher the force required the larger in diameter the part. The longer the stroke, the higher the minimum height. Make sure that you follow all of the guidelines shown in the Do's and Don'ts section below.

4. SELECT THE END CLOSURES AND AIR INLET SIZE:

Most Airstroke actuators are available with either permanently attached plates or bead ring (flange) attachments. (See end closure options chart for attachments, air fittings, and attachment locations.) Most parts with plates are available with either 1/4" or 3/4" NPT air fittings.

Do's and Don'ts

DOWN AND UP STOPS

Positive stops in both directions (compression and extension) should always be used with Airstroke actuators.

1. In COMPRESSION, the minimum height shown for each air spring is at, or slightly above the PINCH POINT of the bellows. The bellows can be damaged if allowed to constantly bottom out; therefore, a down stop is required to prevent this. An external down stop can be something as simple as a steel block and should be sized at or slightly greater than the minimum height of the Airstroke actuator. If an external down stop cannot be used, many parts are available with internal rubber bumpers. See Engineering Manual and Design Guide.
2. In EXTENSION, an up stop is required to prevent the air spring from overextending. Failure to install an up-stop could result in a reduced bellow life, and allow the end crimp seal to open up.

There are many ways to design-in an up-stop, including a) a chain, b) a cable, or c) contacting a metal stop, etc.

RETURN

An Airstroke actuator is a single acting device. To return the actuator to its minimum height for another cycle or stroke, some return force must be used. Gravity acting on the load may be all that's required. (Refer to the order block section in the Engineering Manual for the force required to return convoluted Airstroke actuators to minimum height.) If the load is not sufficient, then a second actuator or coil spring may be required.

GUIDING

An Airstroke actuator follows the path of least resistance; therefore, the actuator should always be guided. This is often easily accomplished in the mounting geometry.

ANGULAR CAPABILITY

An Airstroke actuator can stroke through an arc without a clevis. Angular motion of up to 30 degrees is possible. When using an actuator with the mounting plates at an angle to each other, observe the following:

- a. Measure force at the height between the plate centers.
- b. Measure maximum height at the side separated the furthest.
- c. Measure minimum height at the side collapsed the most.

These measurements must fall within the guide lines for that particular part.

Reversible sleeve type (1T) parts may also stroke through an arc. In this case, care must be taken to prevent the bellows from rubbing (internally) against itself where it rolls over the piston.

HORIZONTAL MISALIGNMENT

The upper and lower bead plate centers (or mounting plate centers in the case of a bead ring type attachment) may be out of line somewhat without injury to the bellows. Our "rule of thumb" for convoluted type actuators is one inch misalignment allowed per convolution. So, a single convoluted air spring may be out of line by as much as 1 inch, a double convoluted by 2 inches, and a triple convoluted air spring by 3 inches.

DESIGN ENVELOPE

Adequate clearance should be provided around the Airstroke actuator to prevent puncturing or rubbing of the bellows. (Refer to the selection guide on page 3 for the maximum diameter at 100 psi for each Airstroke bellows.)

STACKING

It is permissible to stack actuators, one on top of another, to increase stroke; however, the center plate (or plates) connecting the two or more Airstroke actuators **MUST BE GUIDED**. Please note that the air spring forces are not additive in this configuration.

FAIL SAFE DEVICES

Some applications require the use of fail safe mechanisms (such as a mechanical lock-out on a scissors lift) to prevent damage or injury in the event of an air system failure.

VACUUM

An Airstroke actuator can withstand a small amount of vacuum without injury to the bellows. The maximum amount of acceptable vacuum is dependent upon the bellow's size, the height in use, and whether it is a two ply or high strength (fabric) air spring. (A high strength Airstroke bellows has a "stiffer" wall than a two ply; therefore, it is less susceptible to dimpling and deformation inward). It is generally best to use only single convoluted air springs under vacuum.

Advantages of:



Why use an Airmount isolator, rather than a coil spring or other type of isolator?

UNSURPASSED ISOLATION CAPABILITY

Airmount isolators can provide the highest degree of isolation of any type vibration isolator. System natural frequencies as low as 60 cycles per minute (1 Hertz) are available. Lower system frequencies can be accomplished by the use of an additional reservoir. In order to achieve similar results from a conventional coil spring isolator, a real deflection of 9 inches would be required.

CONSTANT ISOLATION EFFICIENCY

Airmount isolators are unique in that the system's natural frequency does not change significantly with changes in load. This unique feature, combined with accurate height control, will allow the use of the same Airmount isolator at each mounting point of an unevenly loaded machine.

EFFECTIVE NOISE REDUCTION

Airmount isolators reduce structurally transmitted noise. They are also quiet in themselves, since there is no spring chatter as found in conventional coil springs.

ACCURATE HEIGHT CONTROL

Airmount isolators provide accurate height control through regulation of internal air pressure. This feature eliminates the reduction in isolation efficiency caused by fatigue and permanent set found in other types of vibration isolators.

WIDE SIZE RANGE

Airmount isolators are capable of isolating loads of 100 pounds per mounting point to over 85,000 pounds per mounting point.

COMPACT INSTALLED HEIGHT

Airmount isolators can carry the loads and provide the isolation described above at installed heights as low as 2.5 inches. Coil springs providing equal isolation would require a free height of 5 to 25 inches.

EXTENDED EQUIPMENT LIFE

Airmount isolators extend equipment life through their superior isolation capabilities.

VERSATILE

Airmount isolators can be used not only to protect structural members from vibrating machinery, but are also widely used to protect delicate equipment from structurally transmitted vibration.

VIBRATING SCREEN

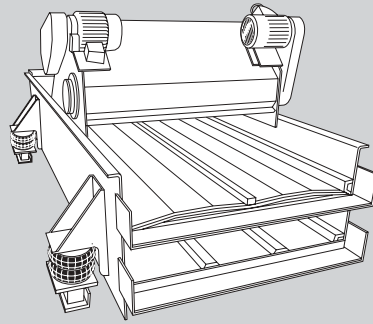

BIN HOPPER

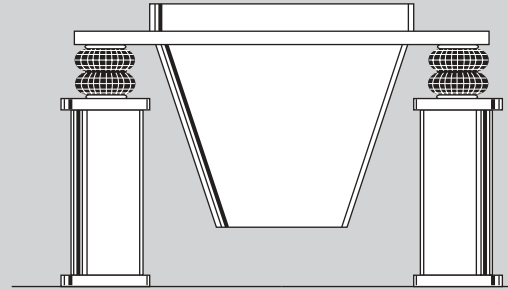

BLOWER AND MOTOR

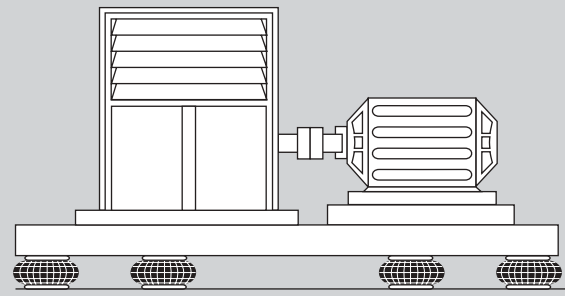

DELICATE ELECTRONIC EQUIPMENT

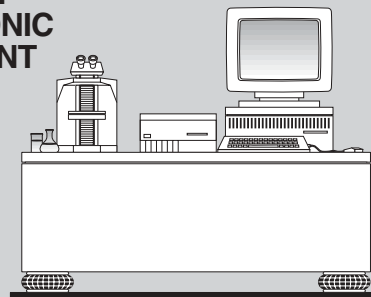

WASHING MACHINE

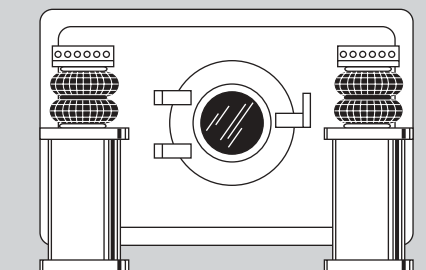

Airmount® Isolator Basics

A detailed discussion of vibration isolation is beyond the scope of this brochure, but the general theory and terms bear some explanation.

In any vibration isolation application, there will be some source of vibration, or disturbance, that generates concern. This disturbance may be coming from the environment. An example would be a coordinate measuring machine in a metal stamping plant whose floor vibrations make delicate measurement impossible. The disturbance may also be generated by a device that affects the surroundings. An example of this could be a vibrating screen or power unit in an office setting.

Although these situations would appear to be distinctly different, they are analytically equivalent.

In any vibration isolation application, the disturbing (forcing) frequency, f_f , is the key parameter in question, and is necessary to select an isolator. The disturbing frequency is typically related in some way to the equipment, usually a rotational speed. This is normally expressed in cycles per minute (cpm) or cycles per second (hertz, hz).

Common examples would be a power unit, where the disturbing frequency would be the motor rotational speed; a vibrating screen, where f_f would be the speed of the eccentrics, or a fan unit where it would be the fan speed. Care must be taken to insure that the lowest unbalanced disturbing speed is used for isolator selection.

Just as the disturbing frequency is a characteristic of the application, the natural frequency, f_n , is a characteristic of the isolation system. In general, the natural frequency is determined by the spring rate of the isolator and the load supported by the isolator. With reference to the Firestone line of air springs, the natural frequency is dependent upon the specific part selected. Natural frequencies are listed on the selection chart for each Firestone air spring.

A good rule of thumb is to select an isolator whose natural frequency is less than or equal to one-third of the disturbing frequency. The lower the natural frequency compared to the disturbing frequency, the greater the effectiveness of the isolation system.

Sample Problem

Consider the example of a fan and motor mounted on a common base. The combined weight of the unit is 6000 lbs. However, due to offset positioning, the loads per mounting point show two at 1400 lbs. each and two at 1600 lbs. The motor speed is 1650 rpm, however, the fan is only going at 800 rpm due to the reduction in the fan drive system. The system is to be mounted on a flat roof top so there are no space constraints.

1. First, we need to determine the smallest diameter part capable of supporting the load at each point.

- The #110 Airmount isolator will carry 1790 lbs. so it will easily do the job. (Note that the 131 would support the lower requirement of 1400 lbs., but would not handle the 1600 lb. load. It is usually best to use the same isolator in all mounting locations if possible.)
- We could also use the #224 Airmount isolator in the double convolution section. In the next step we will look at both parts.

2. From the discussion above and the information in the sample problem, we know that the lowest disturbing frequency needs our attention. That would be the speed of the fan at 800 cpm. Comparing the Isolation percentage in the far right column of the selection guide on page 8, we see the following:

- At 800 cpm the #110 isolator will yield a 95.8% isolation.
- The #224 Airmount isolator will provide 97.5%. While this doesn't seem like a big difference, the 224 will transmit 40% less energy through to the roof. (95.8%

isolation is 4.2% transmission, 97.5% isolation is 2.5% transmission. 2.5 is 40% less than 4.2) This is often the difference between a satisfactory isolation system and one that will not be appreciated.

- It should be noted here that if we had used a disturbing frequency other than 800 cpm, we could have used the graph on page 9. Let's suppose that the forced frequency was 600 cpm, or 10 hz. Our natural frequency for a #224 is shown as 124 cpm on the selection chart. Rounding this off to 120 cpm or 2 hz, we can find where these two values intersect on the graph. This point is very near the diagonal line referencing 95% isolation. We would use this number to determine our approximate effectiveness.
3. A quick check of the selection chart shows that the design height of a #224 is 6.5 inches. This value should be used in designing the surrounding equipment. Paying specific attention to the Do's and Don'ts, we see that we should provide safety stops at 6.0 and 7.0 inches to prevent the system from over-traveling in case of some extreme disturbance.
4. Although for the purposes of this discussion it is not necessary to be extremely exact, in many designs it will be more important. If you are designing an isolation system, we strongly urge you to obtain our [Engineering Manual and Design Guide](#).

Contact Firestone, or your local Firestone distributor, to discuss any more complicated problems.

AIRMOUNT® ISOLATORS

Style Number	Design Height	Load (at Design Height) at 100 PSIG (pounds)	Natural Frequency (@ 80 PSIG) f_n (cpm)	% of Isolation at Forced Frequency	
				400 CPM %	800 CPM %

SHAPED SLEEVE

1M1A-0	2.5	570	220		91.8
1M1A-1	3.0	593	162	90.0	95.5
2M1A	DO NOT USE 2M1A AS AN AIRMOUNT ISOLATOR				
2M2A	2.0	198	232		90.8

SINGLE CONVOLUTION

16	3.0	1120	237		90.3
16ST	3.0	1000	240	87.0	97.0
131	3.5	1510	181	74.4	94.6
110	4.5	1790	162	80.2	95.7
116	4.5	2360	163	80.2	95.7
116-1	5.5	2530	139	86.3	96.9
115	4.5	3010	166	79.1	95.5
19	5.0	5680	156	82.1	96.0
19-75	5.5	5260	156	82.0	96.0
113	5.0	8800	150	83.6	96.4
113-1	5.5	10,200	133	87.7	97.2
153-2	6.0	12,385	121	89.9	97.7
119**	5.0	14,520	138	86.5	96.9
121**	5.0	18,450	142	85.5	96.7
126**	5.0	28,290	133	87.5	97.1
138-1.5	6.0	41,620	124	89.3	97.5
148-1	5.5	85,200	118	90.5	97.8

DOUBLE CONVOLUTION

25	5.5	1180	154	82.5	96.1
255-1.5	6.0	1524	129	87.6	97.2
224	6.5	1940	126	89.0	97.5
26	8.0	2140	111	91.6	98.0
20	8.5	2720	116	90.7	97.8
20-2	10.0	3238	97	93.7	98.5
22	9.5	5400	106	92.4	98.2
22-1.5	10.5	5310	106	92.4	98.2
21	9.5	8330	105	92.6	98.3
21-2	10.5	9210	95	94.1	98.6
233-2	11.25	9917	89	95.0	98.8
28**	9.5	12,120	101	93.2	98.4
203**	9.5	18,890	97	93.7	98.5
29**	9.5	25,350	92	94.4	98.7
200	9.5	34,620	93	94.2	98.6
215	10.5	40,980	86	95.1	98.8
248-2	11.0	79,730	83	95.5	98.9

TRIPLE CONVOLUTION

352	13.5	6463	77	95.9	99.0
313	13.0	8960	82	95.6	98.9
333	14.7	8940	77	96.1	99.1
312**	13.0	13,530	80	95.8	99.0
323**	13.0	19,660	77	96.1	99.1
320**	14.0	26,740	73	96.5	99.2
321	15.0	41,900	70	96.8	99.2
348-3	15.0	82,540	68	97.0	99.3

REVERSIBLE SLEEVE

1X84D-1*	8.0	680	71	96.8	99.2
4001	5.5	380	105	92.7	98.3
7002	4.5	820	114	91.2	97.9
7010	8.0	810	83	95.5	98.9
7012	8.5	1000	75	96.3	99.1
1T12E-3	10.5	770	73	96.5	99.2
1T14C-1	10.0	3220	86	95.1	98.8
1T14C-3	11.0	3240	76	96.2	99.1
1T14C-7	13.5	3240	64	97.4	99.4
1T15T-1	7.0	5490	97	93.7	98.5
1T15S-6	12.0	5340	74	96.5	99.1
1T15L-4	11.0	6930	82	95.6	98.9
1T15M-0	7.5	6990	94	94.1	98.6
1T15M-2	9.5	7510	86	95.2	98.8
1T15M-4	12.5	7170	71	96.8	99.2
1T15M-6	15.0	7000	67	97.1	99.3
1T15M-9	18.5	7120	58	97.8	99.5
1T19L-7	15.0	8898	70	96.8	99.2
1T19L-11	18.0	8711	63	97.5	99.4

* Do not inflate above 80 PSI.

† Except for 1X84D-1.

** When using the rolled plate end closure option, add .7 inch to heights shown.

Airmount® Isolator Selection Procedure

Refer to the **selection guide** on this page for Airmount isolator capabilities.

1. LOAD CAPACITY

Select one or two Airmount isolators that can support the load at each mounting point. It is normally best to design for pressures in the 60 to 80 psig range. Consider only the 1M1A and the single and double convoluted types at first. Please notice that in the range of 210 to 63,890 pounds you will, in most cases, find both a single and double convoluted style part which will support the load.

2. DETERMINE ISOLATION EFFECTIVENESS

Locate the forced frequency on the vertical axis of the chart on page 9. Locate the natural frequencies of the parts selected above and find these values on the horizontal axis of the Isolation Chart. At the intersection of the forced frequency and natural frequency lines you will be able to determine the approximate percentage of isolation by comparing this point with the diagonal lines representing these percentages.

3. DETERMINE DESIGN HEIGHT

The Airmount isolator SHOULD BE USED AT THE DESIGN HEIGHT GIVEN. The double convoluted part is used at a design height somewhat higher than its single convolution equivalent. Make sure that the design height falls within the height restrictions. Also, the double convoluted part will show a higher percentage of isolation (less transmitted vibration) than the single convoluted air spring. The reason for this is that the double convoluted part has a greater internal volume of air than the single convoluted version of the same size. At disturbing frequencies in the 400 to 800 cpm range, the double convoluted part is a significantly better vibration isolator than the single convoluted part. At disturbing frequencies of 800 to 1500 cpm the gap closes considerably. At frequencies of 1500 cpm and above, the difference is negligible.

4. DETERMINE EXACT INTERNAL PRESSURE AND ISOLATION EFFECTIVENESS

The chances are that your specific vibration problem does not fall neatly into the load and disturbing frequency criteria as presented in the selection guide. Therefore, once a preliminary part selection has been made, turn to the individual data page in the [Engineering Manual and Design Guide](#) for that part in order to determine the specific internal pressure required and the percentage of isolation attainable.

CONSULT FIRESTONE FOR USE AS AN AIRMOUNT†

Airmount Vibration Isolation Chart

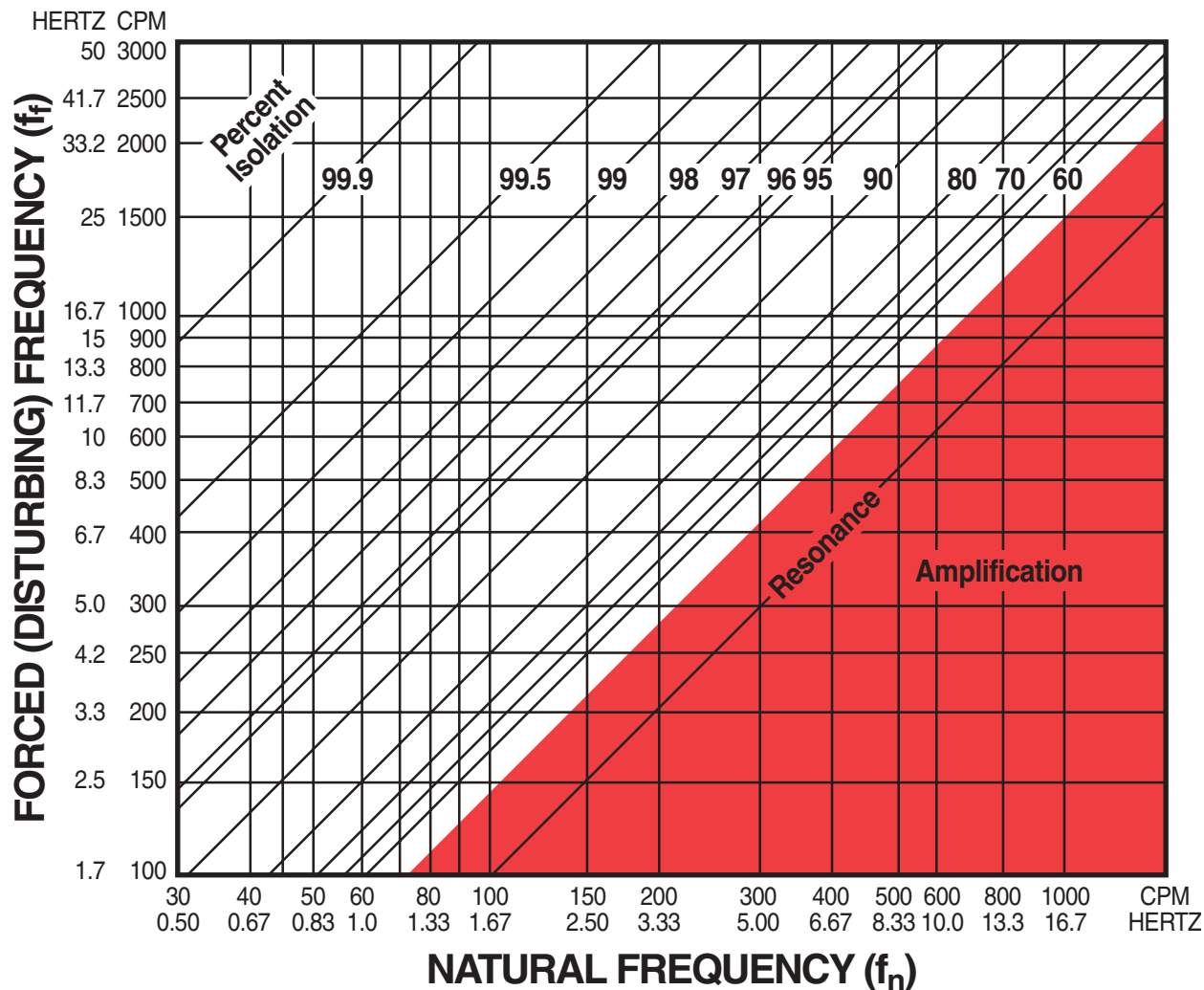

Airmount Vibration Isolator Do's and Don'ts

CENTER OF GRAVITY

Airmount isolator systems are inherently soft (easily deflected); therefore, precautions must be taken to ensure that the system is stable. First, consider the location of the center of gravity (c.g.). Ideally, the Airmount isolators should be located on the same plane (parallel to the ground) as the center of gravity. Where this is not possible, follow this guideline: The distance between the narrowest mounting points should be at least twice the height of the center of gravity above the mounting points.

LATERAL RATES AND STABILITY

A single and double convoluted air spring SHOULD BE USED AT THE DESIGN HEIGHT GIVEN, because that is the point of maximum lateral rate or stability. The lateral rate decreases as the isolator's height decreases. Consider a #22 at 80 psig:

Height	Lateral Rate	Vertical Rate
9.5 inch (design height)	325 lbs./in.	1,400 lbs./in.
8.5 inch	212 lbs./in.	1,500 lbs./in.
7.5 inch	Unstable	—

Notice that the #22 becomes unstable in the horizontal, or lateral, direction when moving down only two inches from design height.

At design height and without an auxiliary reservoir, the single and double convoluted parts follow this pattern; i.e., the lateral rate varies from 1/5 to 1/2 of the vertical rate (only the larger high strength parts get as high as 1/2).

PLUMBING SYSTEMS

There are three basic ways of controlling an air suspended isolation system:

1. **Tank Valve System**—With a TANK VALVE in each isolator, each air spring can be inflated individually. The pressure in each must be checked periodically, because air will permeate through the bellows.

For an idea of the permeation rate, a #116 will lose approximately 30 psig over a period of one year (from 100 psig to 70 psig).

2. **Three Point Regulated System**—The Airmount isolators can be connected directly to the factory compressed air system using pressure regulating valves. This eliminates the need for periodic inspections. The air springs should always be connected in clusters so the mass is supported with only THREE REGULATORS.

3. **Three Point Leveled System**—Automatic height control can be provided by adding height control valves to the system. Again, there should be only THREE POINTS OF CONTROL, or in this case, three leveling valves. Attempting to use more than three control points often results in the valves “hunting” or “fighting one another”. There are sensing systems available to control heights within $\pm .001$ inch. Truck type leveling valves can provide accuracy to $\pm 1/16$ inch.

DESIGN ENVELOPE

Adequate clearance should be provided around the isolator to prevent puncturing or rubbing of the bellows. (Refer to the selection guide on page 3 for the maximum diameter at 100 psi for each Airmount bellows.)

SAFETY STOPS

It is normally recommended that positive stops be installed in all directions; (i.e., in compression, in extension, and for lateral displacements.) Positioning of the vertical stops depends upon the amplitude of movement, both during normal operation and during startup and shutdown. A good “rule of thumb” is $\pm 1/2$ inch from design height for vertical stops and also $\pm 1/2$ inch (horizontally) for lateral stops.

INITIAL INSTALLATION

NEVER use Airmount isolators to lift equipment into place, due to the lateral instability at lower air spring heights as discussed previously. The equipment should be rested on stops set slightly below design height and raised into position for isolation.

TRIPLE CONVOLUTED AND REVERSIBLE SLEEVE TYPE PARTS

Both of these types are unstable laterally (except for the 1M1A). Due to low natural frequencies, both can be excellent isolators; however, do not use these two types as Airmount isolators without consulting Firestone (for special guidelines and precautions).

STARTUP AND SHUTDOWN/ RESONANCE AND AMPLIFICATION

Resonance is the condition where the forced frequency of the vibrating system is at the natural frequency of the suspension. When this happens, AMPLIFICATION of movement occurs. So, while a machine is building up to speed and slowing down, the amplitude of movement may be exaggerated. The longer the machine takes to go through resonance (to build up to, or slow down from full operating speed), the larger the amplitude of movement.

ISOLATING AN UNBALANCED MASS

The primary concern in this case is the amplitude of movement. It is dependent on:

- 1) The ratio of the unbalanced moving mass to the total suspended mass and,
- 2) The ratio of the speed of the unbalanced moving mass (forced frequency) to the natural frequency of the Airmounts.

The addition of damping to the isolation system (shock absorbers) will reduce the large amplitude of movement experienced during resonance.

If the amplitude of movement is too great, one possible solution would be to add an inertia base in order to increase the ratio of the total suspended mass to the moving unbalanced mass. A good “rule of thumb” is 10:1, respectively.

LOW PRESSURE OPERATION

The lateral rate of a single and double convoluted style isolator decreases with decreasing internal air pressure (becomes unstable). Consult Firestone if you plan on operating an Airmount isolator at less than 40 psig.

EFFECT OF AN AUXILIARY RESERVOIR

There is a direct relationship between natural frequency and isolation effectiveness. Generally, the lower the natural frequency, the better the isolator (or higher percentage of isolation). As previously mentioned, a double convoluted Airmount isolator has a lower natural frequency than a single convoluted type (of the same size) because it has more internal air volume. We can use this principle to lower the natural frequency of an air spring by adding an auxiliary reservoir (pressure vessel) externally to the isolator. This effectively increases the air spring volume and reduces its natural frequency.

In order for the reservoir to work properly, there must be a free flow of air between the air spring and reservoir. Therefore, it should be mounted as close as possible to the isolator. A bead ring attachment is the best end closure choice for this, as the hole in the mounting plate can be sized as large as the inside diameter of the bellows. A 3/4" NPT air inlet will restrict the flow of air somewhat on large parts, but it can be used where amplitudes are small.

DAMPING

Damping is defined as a ratio of System Damping to Critical Damping. The damping ratio inherent in an Airmount isolator is in the order of .03. This damping number is so small that the formulas we use assume it to be zero.

Standard Types

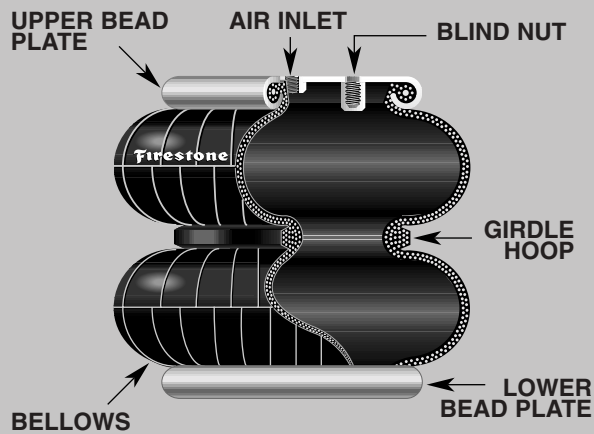

CONVOLUTED AIR SPRINGS WITH CRIMPED BEAD PLATES
(#22 is shown)

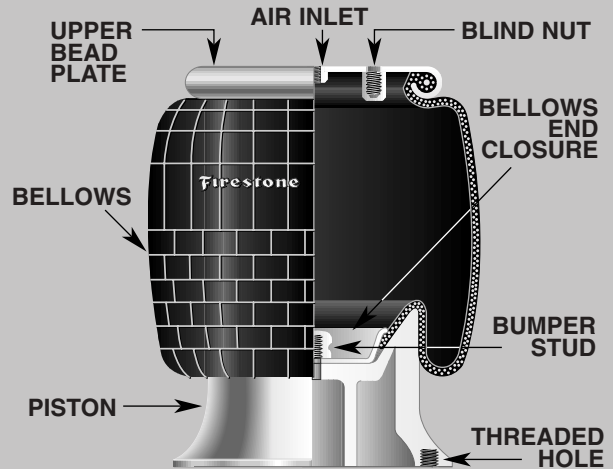

REVERSIBLE SLEEVE AIR SPRINGS WITH CRIMPED BEAD PLATES
(1T15M-6 is shown)

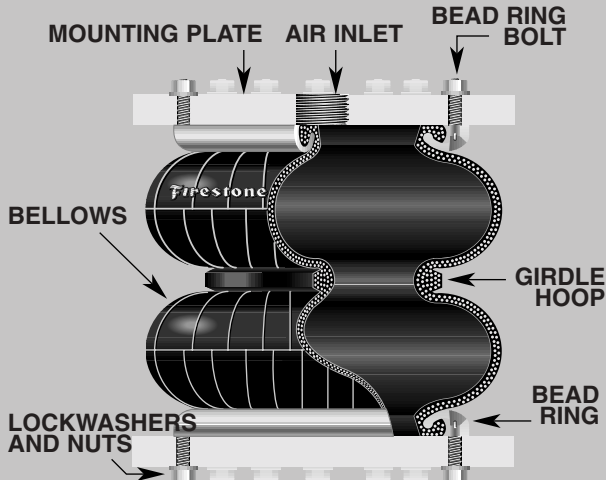

CONVOLUTED AIR SPRINGS WITH STEEL BEAD RINGS
(#22 is shown, with bead rings instead of crimped bead plate)

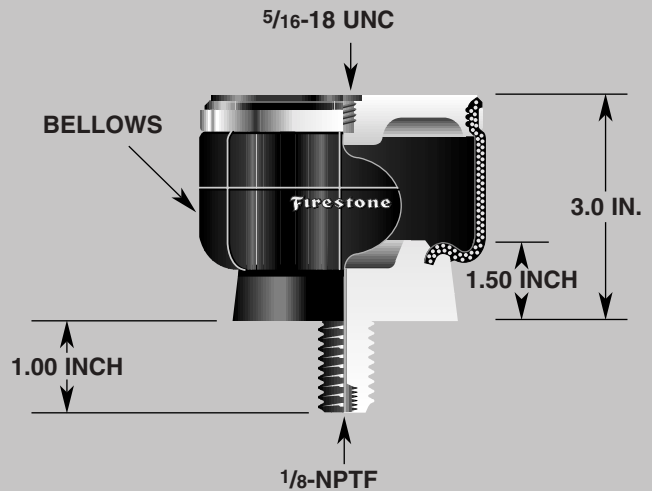

1M1A AIRSTROKE actuator

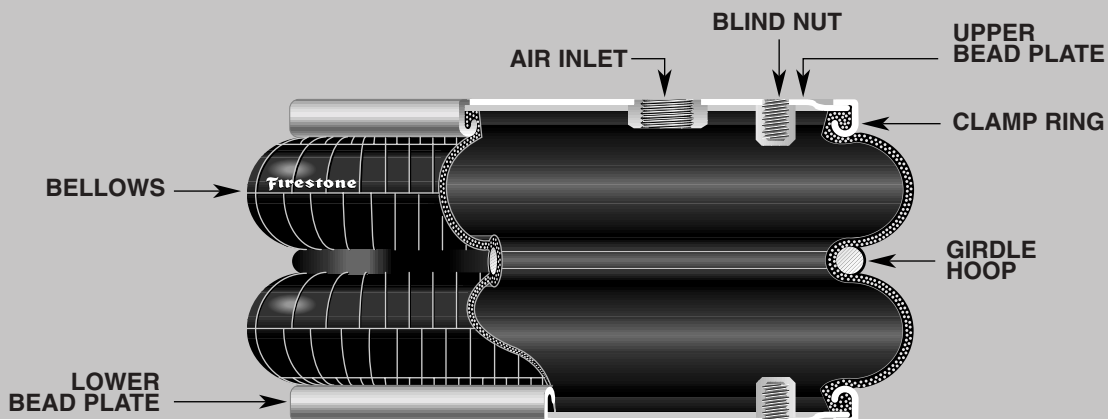

LARGE CONVOLUTED AIR SPRINGS WITH ROLLED PLATES
(#203 is shown, with rolled plates instead of bead rings)

TYPICAL APPLICATIONS

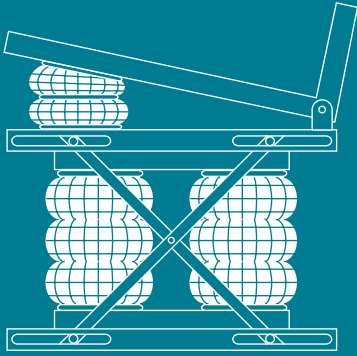

SCISSORS LIFT AND TILT TABLE

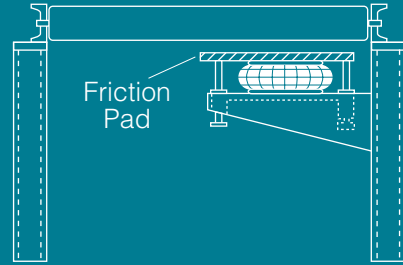

ROLLER FRICTION BRAKE

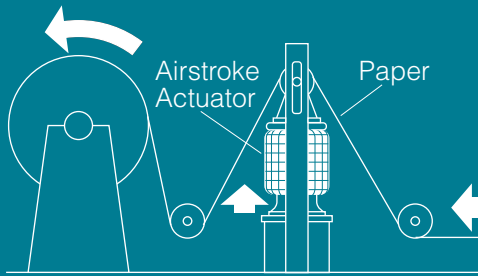

WEB TENSIONING DEVICE

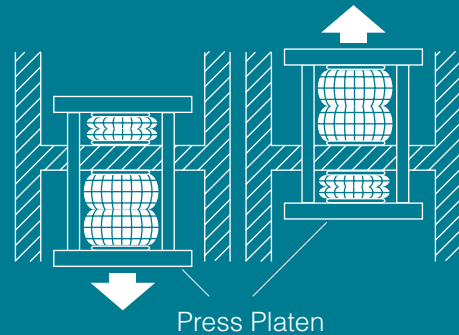

FORMING PRESS

DISTRIBUTED BY:

Request our Engineering Manual & Design Guide for more extensive and specific part information.

Firestone

World's Number 1
Air Spring.

FIRESTONE INDUSTRIAL PRODUCTS COMPANY

12650 Hamilton Crossing Blvd.
Carmel, Indiana 46032
1-800-888-0650
www.firestoneindustrial.com

PLEASE NOTE:

The information contained in this publication is intended to provide a general guide to the characteristics and applications of these products. The material, herein, was developed through engineering design and development, testing and actual applications and is believed to be reliable and accurate. Firestone, however, makes no warranty, express or implied, of this information. Anyone making use of this data does so at his/her own risk and assumes all liability resulting from such use. It is suggested that competent professional assistance be employed for specific applications.